

**"MAKING ENERGY EFFICIENCY AND CONSERVATION
A WAY OF LIFE"**

For more information:



Energy Utilization Management Bureau
Department of Energy

3/F Annex Building, Energy Center, Rizal Drive
Bonifacio Global City, Taguig City, Philippines, 1632
(02) 8479-2900 local 214, 8840-2243
<https://www.doe.gov.ph>



GUIDELINES ON ENERGY CONSERVING DESIGN OF BUILDINGS

2020 Edition



The background of the cover is a complex architectural wireframe or blueprint. It features a grid of lines and various geometric shapes, including circles and rectangles, overlaid on a perspective view of a building's structure. The lines are thin and light gray, creating a technical and modern aesthetic.

GUIDELINES ON ENERGY CONSERVING DESIGN OF BUILDINGS

2020 Edition



PREFACE

Philippine Copyright 2020

by

Department of Energy (DOE), Philippines

All rights in these Guidelines are reserved. No copyright is claimed to the portions of the Guidelines containing copies of the laws, ordinances, regulations, administrative orders or similar documents issued by government or public authorities. All other portions of the Guidelines are covered by copyright. Reproduction of the other portions of the Guidelines covered by copyright shall require the consent of the Department of Energy, Philippines.

First Printing: December, 2020

This publication was produced by the Department of Energy with the support of the European Union through the Access to Sustainable Energy Programme (ASEP). Its contents are the sole responsibility of the Department of Energy and do not necessarily reflect the views of the European Union.

*Image Credits:
Bedneyimages, Freepik
Joel Filipe, Unsplash
photovoltaic_needpix*

With the enactment of Republic Act No. 11285, otherwise known as the Energy Efficiency and Conservation Act of 2019, the policy of the State towards the efficient and judicious utilization of energy has been strengthened further. The law mandates that all building constructions, new and building retrofits, shall comply with minimum requirements set in the Guidelines on Energy Conserving Design of Buildings.

These Guidelines address the need to provide energy efficiency guidance in the design and construction of buildings in the Philippines. They form part of the efforts of the Department of Energy (DOE), with technical assistance from the European Union-supported Access to Sustainable Energy Programme (ASEP), to ensure the use of energy-efficient systems in the building sector.

The previous Guidelines were developed in 2007 by DOE through the Philippine Efficient Lighting Market Transformation Project as supported by the United Nations Development Programme – Global Environment Facility.

These present Guidelines were updated through a consultative process facilitated by the Department of Energy-Energy Utilization Management Bureau (DOE-EUMB) and participated in by the Institute of Integrated Electrical Engineers of the Philippines, Inc. (IIEE), Philippine Society of Mechanical Engineers (PSME), and Energy Efficiency Practitioners Association of the Philippines (ENPAP 4.0), together with various experts, professionals, and stakeholders from the Department of Public Works and Highways (DPWH), Department of Environment and Natural Resources (DENR), DOE-Lighting and Appliance Testing Laboratory (DOE-LATL), Manila Electric Company (MERALCO), Philippine Lighting Industry Association (PLIA), Philippine Green Building Initiative (PGBI), Philippine Green Building Council (PGBC), and United Architects of the Philippines (UAP).

In these updated Guidelines, technical requirements were provided based on two Building Codes that impact energy performance of buildings, i.e. the National Building Code and the Philippine Green Building Code. Obligations of building owners consistent with the Energy Efficiency and Conservation Act were cited in Appendix A. Renewable energy systems and equipment were added in line with the Renewable Energy Act of 2008. Certain sections were also updated based on international standards, notably the American Society of Heating, Refrigerating and Air Conditioning Engineers (ASHRAE).

Though conscientious efforts have been exerted to make the contents of these Guidelines as technically sound as possible, it is advised that they be applied by duly qualified and competent professionals. Please address any concern or issue on the applicability, accuracy, or completeness of this document to DOE-EUMB for further validation and interpretation.

Comments on the Guidelines, including omissions and errors, as well as conflicts with accepted international standards, are most welcome and will be highly appreciated. All suggestions will be studied and considered for inclusion in the Guidelines next edition.



Republic of the Philippines
DEPARTMENT OF ENERGY
Energy Center, Rizal Drive, Bonifacio Global City, Taguig City

MESSAGE



Greetings!

The Department of Energy (DOE) is firmly committed to the nation's energy security and sustainability. This has been reinforced by the enactment of Republic Act 11285 or the Energy Efficiency and Conservation Act, which formalized the DOE's push for the conscious and judicious use of our scarce energy resources through the utilization of energy-efficient technologies and the improvement of our energy consumption habits.

Consistent with our advocacy for the creation of "green" buildings, we endorsed the Philippine Green Building Council's proposal, which was approved by the Office of the President under Proclamation Order 1030 declaring September 8 of every year as "National Green Building Day". This is part of our commitment to lower greenhouse gas emissions through increasing public awareness on energy-efficient technologies and practices, and in the standardization of responsible construction practices that will maximize the use of limited materials.

These guidelines were developed during the peak of the COVID-19 pandemic. As such, we have also included the use of new air filtration technologies combined with proper ventilation in buildings to help mitigate the spread of the virus and other communicable airborne diseases.

Given that building construction is viewed as a positive economic indicator, it is our hope that the number of energy-efficient buildings would rise within the immediate future as we recover from the losses brought forth by the pandemic. In this regard, we partnered with the Board of Investments to create programs that will hopefully jumpstart the economy by providing both fiscal and non-fiscal incentives to those who will employ energy-efficient technologies.

Energy efficiency should not be viewed solely in terms of energy and monetary savings. Rather, it could be considered a sub-sector of the energy industry that would help spur employment opportunities and advance more accessible, affordable, and improved energy technologies.

Of course, none of this would have been possible without the unwavering support of our development partners, the European Union-Assisted Access to Sustainable Energy Program (EU-ASEP), their experts, and all those who have given their time and effort in crafting these guidelines. We would also like to thank the Department of Public Works and Highways for evaluating these Updated Guidelines, which would serve as a reference to the Philippine Green Building Code and the infrastructure standard in the years to come.

Maraming salamat po.

Alfonso G. Cusi
Secretary



Republic of the Philippines
DEPARTMENT OF ENERGY

DEPARTMENT CIRCULAR NO. DC2020-12-0026

ADOPTION OF THE GUIDELINES ON ENERGY CONSERVING DESIGN OF BUILDING

WHEREAS, Section 2 of Republic Act No. 7638 or the "Department of Energy (DOE) Act of 1992" states that it is the policy of the State to ensure a continuous, adequate, reliable, and economic supply of energy through, among others, judicious conservation, renewal, and efficient utilization of energy, to keep pace with the country's growth and economic development;

WHEREAS, Sections 4 and 5 of the DOE Act of 1992 as amended, mandates for the formulation of policies for the planning and implementation of a comprehensive program for the efficient supply and economical use of energy consistent with the approved national economic plan, and the provision for a mechanism for the integration, rationalization and coordination of the various energy programs of the Government with a preferential bias for environment-friendly, indigenous, and low-cost sources of energy;

WHEREAS, Section 3 of the Republic Act No. 11285 or the "Energy Efficiency and Conservation Act" (EEC Act) provides for the establishment of a framework for introducing and institutionalizing fundamental policies on energy efficiency and conservation, including the promotion of efficient and judicious utilization of energy, increase in the utilization of energy efficiency and renewable energy technologies, and the delineation of responsibilities among various government agencies and private entities;

WHEREAS, Section 18 of the EEC Act states that new building construction and retrofit of buildings shall comply with the minimum requirements specified in the Guidelines on Energy Conserving Design on Buildings;

WHEREAS, Section 57 of Department Circular No. DC2019-11-0014 or the "Implementing Rules and Regulations of the EEC Act" (EEC-IRR) provides that Local Government Units (LGUs) shall implement measures in the building permit issuances to ensure appropriate and effective implementation of energy efficiency and conservation for new and existing buildings for commercial and industrial use such as hospitals, educational facilities, exhibition centers, government offices, and military facilities;

WHEREAS, conservation and efficient utilization of energy are among the major strategies of the Government to realize energy self-sufficiency and reduce environmental impacts of energy generation and utilization as instituted in the Philippine Energy Plan (PEP) and the National Energy Efficiency and Conservation Program (NEECP);

WHEREAS, the adoption of the Guidelines on Energy Conserving Design of Buildings will lead to the adoption energy efficiency in the building energy sector;

WHEREAS, a Call of Comments on the draft "Guidelines on Energy Conserving Design for Buildings" was posted in the DOE Website and comments were received until the conduct of each Virtual Public Consultations; and

WHEREAS, the DOE conducted Virtual Public Consultation attended by various stakeholders nationwide on 15-16 September 2020, 16 October 2020 and 27 November 2020 on the draft "Guidelines on Energy Conserving Design for Buildings".

NOW, THEREFORE, for and in consideration of the foregoing premises and pursuant to its mandate under the EEC Act and EEC-IRR, the DOE hereby orders the following:

Section 1. Title. This Department Circular shall be known as the "Adoption of the Guidelines on Energy Conserving Design of Buildings." Attached is the Guidelines on Energy Conserving Design of Buildings, 2020 Edition.

Section 2. Continuous Improvement. Recognizing the continuous advancements in the energy efficiency and conservation, and renewable energy technologies, systems and practices, the Energy Utilization Management Bureau (EUMB) shall support the improvements in the Guidelines on Energy Conserving Design of Buildings through revisions and/or updates within three (3) years unless sooner required: *Provided That*, any revision and/or update shall be indicated by the year of its effectivity.

Moreover, EUMB shall coordinate with the Department of Public Works and Highways – National Building Code Development Office (DPWH – NBCDO) for the integration of Guidelines on Energy Conserving Design of Buildings in the Philippine Green Building Code.

Section 4. Information, Education and Communication Activities. Pursuant to Section 85 of the EEC IRR, the EUMB in partnership with DPWH – NBCDO shall develop and undertake a national awareness and advocacy program covering energy efficiency and conservation, capacity and capability building for LGUs, and pursue partnership with relevant stakeholders for the appreciation of this Department Circular.

Section 5. Repealing Clause. The provisions of other circulars, orders, issuances, rules and regulations, which are inconsistent with the provisions of this Department Circular are hereby repealed, amended, modified or superseded accordingly.

Section 6. Separability Clause. If for any reason, any section or provision of this Department Circular is declared unconstitutional or invalid, such parts not affected shall remain in full force and effect.

Section 7. Effectivity. This Department Circular shall take effect fifteen (15) days following its publication in at least two (2) newspapers of general circulation. A copy of this Department Circular shall be filed with the University of the Philippines Law Center - Office of the National Administrative Register.

Issued at Energy Center, Bonifacio Global City, Taguig City.

ALFONSO G. CUSI
Secretary

DEC 22 2020



TABLE OF CONTENTS

Preface	<i>i</i>
Message from the Department of Energy.....	<i>iii</i>
Adoption of the Guidelines on Energy Conserving Design of Buildings.....	<i>v</i>
Tables.....	<i>x</i>
Figures.....	<i>xii</i>

Section I. Purpose.....	1
Section II. Definition of Terms.....	3
Section III. Application and Exemption.....	15
3.1 Application.....	15
3.2 Exemptions.....	15

PART I BUILDING ENVELOPE

Section IV. Thermal Performance of the Building Envelope	
4.1 Scope.....	17
4.2 Overall Thermal Transfer Value (OTTV) Method....	17
4.3 Prescriptive Method.....	26
4.4 Shading Devices and Determination of the Shading Coefficient.....	28
4.5 Airtightness of the Building Envelope.....	30
4.6 Reflectance of the Roof.....	31
4.7 Required Design Documentation.....	32

PART II MECHANICAL SYSTEMS

Section V. Air Conditioning and Ventilating System.....	25
5.1 Scope.....	33
5.2 Load Calculation.....	33
5.3 System Design and Sizing.....	35
5.4 Fan System Design Criteria	37
5.5 Pumping System Design Criteria	38
5.6 Air Distribution System Design Criteria.....	40

5.7 Controls.....	40
5.8 Chiller Plant Insulation.....	43
5.9 Air Handling System Insulation.....	44
5.10 Air Conditioning Equipment.....	45
5.11 Heat Recovery.....	47
5.12 Thermal Comfort in Non-Air-Conditioned Buildings.....	48
Section VI. Steam and Hot Water System.....	67
6.1 Scope.....	67
6.2 System Design and Sizing.....	67
6.3 Minimum Equipment Efficiency.....	68
6.4 Hot Water Temperature.....	69
6.5 Controls.....	69
6.6 Piping Insulation.....	70
6.7 Waste Heat Recovery and Utilization.....	71

PART III

ELECTRICAL SYSTEMS

Section VII. Lighting.....	77
7.1 Scope.....	77
7.2 Exemptions.....	77
7.3 General Requirements of Energy-Efficient Lighting Design.....	77
7.4 Lighting Power Density (LPD).....	81
7.5 Lighting Controls.....	81
7.6 Control Location.....	84
7.7 Required Design Documentation.....	84
Section VIII. Electric Motors.....	91
8.1 AC Motors.....	91
8.2 High Efficiency Motors.....	95
8.3 Starting and Control Methods for Electric Motors.....	97
8.4 DC Motors.....	99
8.5 DC Motors with Inverters (DC Drives).....	100
8.6 Pumps.....	100

8.7 Escalators and Walkways.....	102
8.8 Elevators/Lift.....	102
8.9 Required Design Documentation.....	103
Section IX. Electric Power and Distribution.....	105
9.1 Scope.....	105
9.2 Transformer.....	105
9.3 Power Supply and Distribution.....	106
9.4 Building Management System.....	112
9.5 Smart Home System.....	112
9.6 Regular Inspection, Maintenance and Audit	113
9.7 Required Design Documentation.....	114
Section X. Renewable Energy (RE) Systems and Equipment...	115
10.1 RE Power Supply Systems.....	115
10.2 Annual Energy Requirements from RE.....	116
10.3 Required Design Documentation.....	117
APPENDICES.....	119

TABLES

- Table 1:** Equivalent Temperature Difference for Walls
- Table 2:** Solar Correction Factor Wall
- Table 3:** Maximum U-value for Roof
- Table 4:** Equivalent Temperature Difference for Roof
- Table 5:** Solar Correction Factor for Roof
- Table 6:** SHGC for Different Window to Wall Ratios (WWR)
- Table 7:** Correction Factor f for External Fixed Shading
- Table 8:** Number of Chillers and Water Chiller Types
- Table 9:** Energy Utilization Index Comparison
- Table 10:** Building Performance Factor
- Table 11:** Piping System Design Maximum Flow Rate in Gallons Per Minute (GPM)
- Table 12:** Energy Efficiency Performance Rating for Room Air Conditioners (2020) Cooling Seasonal Performance Factor
- Table 13:** Values of “a”
- Table 14:** Air Intake Minimum Separation Distance
- Table 15:** Minimum Ventilation Rates in Breathing Zone
- Table 16:** Minimum Exhaust Rates
- Table 17:** Airstreams or Sources
- Table 18:** Typical Model Code Exhaust Flow Rates for Conventional Type 1 Hood
- Table 19:** Maximum Water Velocity to Minimize Erosion
- Table 20:** Minimum Insulation Thickness for Various Pipe Sizes
- Table 21:** Standard Rated Conditions for Air Conditioning Systems
- Table 22:** Minimum Performance Rating of Various Air Conditioning Systems
- Table 23:** Size of Opening for Natural Lighting and Ventilation
- Table 24:** Fresh Air Supply for Mechanical Ventilation
- Table 25:** Maximum Net Exhaust Flow Rate, cfm per Linear Foot of Hood Length
- Table 26:** Minimum Duct Insulation R-Value
- Table 27:** Minimum Piping Insulation Thickness Cooling Systems
- Table 28:** Air Conditioning Checklist
- Table 29:** Minimum Performance Ratings of Steam and Hot Water Systems Equipment
- Table 30:** Baseline Thermal Efficiency Levels for Commercial Water Heater Equipment
- Table 31:** Baseline Standby Loss Levels for Representative Commercial Water Heater Equipment
- Table 32:** Minimum Pipe Insulation (Heating System)
- Table 33:** Minimum Piping Insulation Thickness and Hot Water Systems
- Table 34:** Renewable Energy Ready Solar Water Heating Checklist
- Table 35:** Steam and Hot Water System Checklist
- Table 36:** Recommended Design Illuminance Levels
- Table 37:** Minimum Energy Performance, Efficacy Ranges, and Color Rendering Indices of Various Lamps
- Table 38:** Recommended Room Surface Reflectances
- Table 39:** Maximum Lighting Power Density for Building Interiors
- Table 40:** Maximum Values for Lighting Power Densities for Building Exteriors
- Table 41:** Control Types and Equivalent Number of Control
- Table 42:** Minimum Acceptable Full Load Efficiency
- Table 43:** IEC-NEMA MEP Rating Values for AC Motors
- Table 44:** Types and Characteristics of Uninterruptible Power Supply (UPS) Systems

FIGURES

- Figure 1:** Schematic Representation of a Window and Related Horizontal Overhang or Vertical Fin
- Figure 2:** Circulation of Outdoor and Indoor Air in an Enthalpy (Energy) Recovery Ventilation
- Figure 3:** Enthalpy or Heat Recovery Wheel
- Figure 4:** Wall Mounted Canopy
- Figure 5:** Single Island Canopy
- Figure 6:** Double Island Canopy
- Figure 7:** Back Shelf Canopy
- Figure 8:** Eyebrow
- Figure 9:** Passover

APPENDICES

- A. Obligations of Building Owners
- B. Sample Calculations for Overall Thermal Transfer Value (OTTV)
- C. Percentage of Solar Radiation Absorbed by Selected Building Materials
- D. Thermal Conductivities of Building Materials
- E. K-Values of Basic Materials
- F. Air Space Resistances for Walls and Roofs
- G. Surface Film Resistances
- H. Glass Thermal Transmittance Values
- I. Glass Performance Data
- J. Glass Performance Data
- K. Glass Performance Data
- L. Glass Performance Data
- M. Glass Performance Data
- N. Exhaust Air Energy Recovery Requirements
- O. Philippine Stations and Climate Zones

Section I. Purpose

- 1.1 To encourage and promote the energy conserving design of buildings and their services to reduce the use of energy with due regard to the cost effectiveness, building function, and comfort, health, safety, and productivity of the occupants.
- 1.2 To prescribe guidelines and minimum requirements for the energy conserving design of new buildings and major renovation of existing buildings that fall and are covered under these guidelines, and provide methods for determining compliance with the same to make the buildings always energy-efficient.

Section II. Definition of Terms

Air

Ambient air – air surrounding a building; the source of outdoor air brought into a building

Exhaust air – air removed from a space and discharged to outside the building by means of mechanical or natural ventilation

Indoor air – air in an enclosed occupiable space

Outdoor air – ambient air that enters a building through a ventilation system, through intentional openings for natural ventilation, or by infiltration

Return air – air removed from a space to be recirculated, or exhaust air

Supply air – air delivered by mechanical or natural ventilation to a space and composed of any combination of outdoor air, recirculated air, or transfer air

Ventilation air – supply air that is outdoor air plus any recirculated air that has been treated for the purpose of maintaining acceptable indoor air quality

Air Conditioning – the process of treating air so as to control simultaneously its temperature, humidity, cleanliness, and distribution to meet the requirements of conditioned space

Air Handling Unit – a device used to regulate and circulate air through a duct as part of an air conditioning system

American Society of Heating, Refrigerating and Air Conditioning Engineers (ASHRAE) – global society founded in 1894, advancing human well-being through sustainable technology for the built environment with focus on building systems, energy efficiency, indoor air quality, refrigeration, and sustainability within the industry

Best Efficiency Point (BEP) – the point along a pump curve where efficiency is the highest. It is the factor to properly assess a pump's operation

Boiler – a self-contained, low-pressure appliance for supplying steam or hot water

British Thermal Unit (BTU) – amount of heat energy needed to raise the temperature of one pound of water by one degree Fahrenheit

Building – a permanent structure, whether private or public, enclosed within exterior walls and a roof, and including all attached apparatus, equipment and fixtures, used for any of a wide variety of activities, such as dwelling, entertainment, worship, commercial, industrial, transport, agriculture, public service, education, health care, etc.

Certified Energy Conservation Officer (CECO) – a professional who obtains a certification as a CECO after demonstrating high levels of experience, competence, proficiency, and ethical fitness in the energy management profession. The CECO is responsible for the supervision and maintenance of the facilities of Type 1 establishments for the proper management of energy consumption and such other functions deemed necessary for the efficient and judicious use of energy.

Certified Energy Manager (CEM) – a licensed engineer who obtains a certification as a CEM after demonstrating high levels of experience, competence, proficiency, and ethical fitness in the energy management profession, and who is chosen by Type 2 designated establishments to plan, lead, manage, coordinate, monitor, and evaluate the implementation of sustainable energy management within their organizations

Coefficient of Performance (COP) – ratio of heating or cooling provided to electrical energy consumed, where higher COPs equate to lower operating costs

Color Rendering – the general expression for the effect of the light source on the color appearance of objects in conscious or subconscious comparison

Color Rendering Index (CRI) – the measure of the degree of color shift, which objects undergo when illuminated by the light source. Values for common light sources vary from 20 to 99. The higher the number, the better the color rendering or color appearance (i.e., less color shift or distortion occurs)

Cooling Seasonal Performance Factor (CPSF) – quotient of Cooling Seasonal Total Load (CSTL) in (kWh) divided by the Cooling Seasonal Energy Consumption (CSEC) in (kWh)

Correlated Color Temperature (CCT) – the absolute temperature (in degrees Kelvin) of the light source. This indicates visual “warmth” or “coolness.” The chromaticity of general lighting lamps falls in the range of 2200 to 7500 K. For interior lighting, the chromaticity values of 4000 K and above are usually described as “cool.” Around 3500 K, light sources have a neutral appearance, but at 3000 K and below, the lighting effect is usually judged as “warm.” Hence, the lower the number, the warmer the light (more red content) and the higher the number, the cooler the light (more blue content).

Covered Buildings – buildings and their systems, which are still to be constructed or under construction, or existing buildings and their systems, which are to undergo or is undergoing expansion and/or modifications, with at least 112.5 kVA of designed total connected electrical loads or has at least 10,000 square meters (m²) Total Gross Floor Area (TGFA)

Delta Conversion On-Line Uninterruptible Power Supply (UPS) – a new technology introduced to eliminate the drawbacks of the Double Conversion On-Line design and is available in the range of 5kVA to 1 MW. Similar to the Double Conversion On-Line design, the Delta Conversion On-Line UPS always has the inverter supplying the load voltage. However, the additional Delta Converter also contributes power to the inverter output.

Under conditions of AC failure or disturbances, this design exhibits behavior identical to the Double Conversion On-Line. In the Delta Conversion On-Line design, the Delta Converter acts with dual purposes. The first is to control the input power characteristics. This active front end draws power in a sinusoidal manner, by minimizing harmonics reflected onto the utility. This ensures optimal conditions for utility lines and generator systems and reduces heating and system wear in the power distribution system. The second function of the Delta Converter is to charge the battery of the UPS by drawing power and converting it to the appropriate direct current (DC) charging voltage.

Design Condition – specified environmental conditions, such as temperature and light intensity, required to be produced and maintained by a system and under which the system shall operate

Designated Establishment – private or public entity in the commercial, industrial, transport, power, agriculture, public works and other sectors identified by the Department of Energy (DOE) as energy-intensive industries based on their annual energy consumption in the previous year or an equivalent annual index; the amount of consumption as indicated in Republic Act (R.A.) No. 11285 and subject to adjustment by the DOE as it deems necessary

Department of Energy (DOE) – the agency created through R.A. No. 7638, otherwise known as the “Department of Energy Act of 1992”, and whose functions were expanded by R.A. No. 9136, otherwise known as the “Electric Power Industry Reform Act of 2001”

Ductwork – a system of ducts for distribution and extraction of air.

Double Conversion On-Line UPS – the most common type of UPS above 10kVA. In the Double Conversion On-Line design, failure of the input AC does not cause activation of the transfer switch, because the input alternating current (AC) is not the primary source, but is rather the backup source. Therefore, during an input AC power failure, on-line operation results in no transfer time. The on-line mode of operation exhibits a transfer time when the power from the

primary battery charger battery/inverter power path fails. While a Standby and Line Interactive UPS will exhibit a transfer time when a blackout occurs, a double conversion on-line UPS will exhibit a transfer time when there is a large load step or inrush current. This transfer time is the result of transferring the load from the UPS inverter to the bypass line. Generally, this bypass line is built with dual Silicon Controlled Rectifiers (SCRs), which are very fast, so similar to the Standby and Line Interactive UPS, the transfer time is very brief, usually 4-6 milliseconds. Both the battery charger and the inverter convert the entire load power flow in this design, which causes reduced efficiency and increased heat generation.

Electric Discharge Lamp – produces light by the passage of an electric current through a vapor or gas, initiating the discharge to fluoresce or light up. There are two kinds of electric discharge lamp; Low Intensity Discharge (e.g., fluorescent) and High Intensity Discharge (e.g., mercury vapor, metal halide, high and low pressure sodium).

End User – any person or entity requiring the supply and delivery of electricity for its own use

Energy – the capacity to do work. Energy takes a number of forms that may be transformed from one into another such as thermal (heat), mechanical (work), electrical and chemical (BTU or kWh). It refers to all types of energy available commercially, including natural gas (liquid natural gas and liquid oil gas), all heating and cooling fuels (including district heating and district cooling), coal, transport fuels, and renewable energy sources.

Energy Audit – the evaluation of energy consumption and review of current energy cost to determine appropriate intervention measures and efficiency projects in which energy can be judiciously and efficiently used to achieve savings. It may refer to a walk-through audit, a preliminary audit, or a detailed audit.

Energy conservation – the reduction of losses and wastage in various energy stages from energy production to energy consumption through the adoption of appropriate measures that are technologically feasible, economically sound, environmentally friendly, and socially affordable

Energy Efficiency – the way of managing and restraining the growth in energy consumption resulting in the delivery of more services for the same energy input or the same services for less energy input

Energy Efficiency Class (EEC) – the level of the product's class, which is based on the Cooling Seasonal Performance Factor (CSPF) display on its energy label

Energy Efficiency Classification – the tiers of EEC according to the ranges of CSPF

Energy Efficiency Ratio – the ratio of net cooling capacity (BTU per hour) to total rate of electric input (Watt) under designated operating conditions

Energy Recovery – includes any technique or method of minimizing the input of energy to an overall system by the exchange of energy from one sub-system of the overall system with another

Energy Recovery Ventilation System – a device or combination of devices applied to provide the outdoor air for ventilation, in which energy is transferred between the intake and exhaust air stream

Enthalpy Recovery Wheel – an energy recovery device that transfers outgoing or exhaust air, i.e. temperature and humidity, to the incoming outdoor air

Equivalent Temperature Difference (TDeq) – the temperature difference which results in the total heat flow through a structure as caused by the combined effects of solar radiation and outdoor temperature

Green Energy Option Program (GEOP) – a mechanism to empower end users to choose renewable energy (RE) in meeting their energy requirements

Heating, Ventilating and Air Conditioning (HVAC) – a system that helps maintain good indoor air quality through adequate ventilation with filtration and provide thermal comfort

Illuminance (E) – a measure of the amount of light falling on a surface. It is the average illumination of a surface and its unit of measure is Lux (lx) = lm/m².

Incandescent Lamp – produces light by the passage of an electric current through a filament, which heats it to incandescence (e.g., tungsten and tungsten-halogen)

Indoor Environmental Quality (IEQ) – a condition inside the building that includes air quality, access to daylight and views, pleasant acoustic conditions, and occupant control over lighting and thermal comfort

Line Interactive UPS – the most common design, where the battery-to-AC power converter (inverter) is always connected to the output of the UPS. Operating the inverter in reverse during times when the input AC power is normal provides battery charging. When the input power fails, the transfer switch opens and the power flows from the battery to the UPS output. With the inverter always on and connected to the output, this design provides additional filtering and yields reduced switching transients when compared with the Standby UPS topology. In addition, the Line Interactive design usually incorporates a tap-changing transformer. This adds voltage regulation by adjusting transformer taps as the input voltage varies. However, the inverter can also be designed such that its failure will still permit power flow from the AC input to the output, which eliminates the potential of single point failure and effectively provides for two independent power paths. This topology is inherently very efficient which leads to high reliability while at the same time providing superior power protection.

Luminaire Efficiency – the ratio between the luminous flux emitted by the luminaire and the luminous flux of the lamp (or lamps) installed in the luminaire

Luminance (L) – the brightness of an illuminated or luminous surface as perceived by the human eye and its unit of measure is cd/m^2

Luminous Efficacy (η) – the efficiency with which the electrical power consumed is converted into light and its unit of measure is lm/W

Luminous Flux (Φ) – the light output of a light source and its unit of measure is Lumen (lm)

Luminous Intensity (I) – the measure of light output in a specified direction and the unit of measure is Candela (cd)

Mechanical Ventilation – ventilation provided by mechanically powered equipment such as motor-driven fans and blowers but not by devices such as wind-driven turbine ventilators and mechanically operated windows

Minimum Energy Performance – a performance standard which prescribes a minimum level of energy performance for the commercial, industrial and transport sectors, and energy-consuming products including appliances, lighting, electrical equipment, machinery and transport vehicles that shall be met or exceeded before they can be offered for sale or used for residential, commercial, transport, and industrial purposes

Natural Ventilation – ventilation provided by thermal, wind, or diffusion effects through doors, window, or other intentional openings in the building

Net Metering – a system, attributed to distributed generation, in which a distribution grid user has a two-way connection to the grid and only charged for his net electricity consumption and is credited for any overall contribution to the electricity grid

Overall Thermal Transfer Coefficient (OTTC) – thermal performance of the building envelope (walls or roof) considering all types of thermal transfer

Pump – a rotating machine consisting of an impeller, a pump casing, bearings, bearing frame, shaft and a mechanical seal. The operating principle is to convert mechanical energy to pressure. The pump impeller accelerates a liquid and as the area of the pump casing expands, the velocity of the fluid is converted to pressure. As a result, pressurized fluid exits the pump discharge. The pump is basically an electro-mechanical device.

Renewable Energy (RE) Resources – energy resources that do not have an upper limit on the total quantity to be used. Such resources are renewable on a regular basis, and whose renewal rate is relatively rapid to consider availability over an indefinite period of time. These include, among others, biomass, solar, wind, geothermal, ocean energy, and hydropower conforming with internationally accepted norms and standards on dams, and other emerging renewable energy technologies.

Renewable Portfolio Standards (RPS) – a market-based policy that requires electricity suppliers to source an agreed portion of their energy supply from eligible RE resources

Seasonal Energy Efficiency Ratio (SEER) – energy efficiency rating for central air conditioners

Solar Factor – the factor for vertical surfaces, which has been experimentally determined for this geographical zone

Solar Heat Gain Coefficient (SHGC) of Glazing – the ratio between the incoming solar radiation behind a glazing and the incoming solar radiation in front of a glazing

Standby-Ferro UPS – was once the dominant form of UPS. This design depends on a special saturating transformer that has three windings (power connections). The primary power path is from AC input, through a transfer switch, through the transformer, and to the output. In the case of a power failure, the transfer switch is opened, and the inverter picks up the output load.

In the Standby-Ferro design, the inverter is in the standby mode, and is energized when the input power fails and the transfer switch is opened. The transformer has a special “Ferro-resonant” capability, which provides limited voltage regulation and output waveform “shaping.” Even though it is a standby UPS by design, the Standby-Ferro UPS generates a great deal of heat because the Ferro-resonant transformer is inherently inefficient. The principal reason why Standby-Ferro UPS systems are no longer commonly used is that they can be fundamentally unstable when operating a modern computer power supply load. All large servers and routers use “Power Factor Corrected” power supplies which, when coupled with the Ferro transformer, can give rise to spontaneous and damaging oscillations.

Standby On-Line Hybrid – the topology used for many of the UPS under 10kVA which are labeled “online.” The standby DC to DC converter from the battery is switched on when an AC power failure is detected, just like in a standby UPS. The battery charger is also small, as in the standby UPS. Due to capacitors in the DC combiner, the UPS will exhibit no transfer time during an AC power failure. This design is sometimes fitted with an additional transfer switch for bypass during a malfunction or overload.

Standby UPS – the most common type used for personal computers, the transfer switch is set to choose the filtered AC input as the primary power source (solid line path), and switches to the battery/inverter as the backup source should the primary source fail. When that happens, the transfer switch shall operate to switch the load over to the battery inverter backup power source (dashed path). The inverter only starts when the power fails, hence the name “Standby.”

Steam System – a steam piping system and controls that work together to supply steam or hot water to heat input devices remote from the boiler

Supplier – refers to any person or entity authorized by the Energy Regulatory Commission (ERC) to sell, broker, market or aggregate electricity to the end users

Temperature Difference between Exterior and Interior (ΔT) – the average annual temperature difference between the outside and inside of an air-conditioned building

Type 1 Designated Establishments – are those with an annual energy consumption of 500,000 kilowatt-hours (kWh) to 4,000,000 kWh for the previous year

Type 2 Designated Establishments – are those with an annual energy consumption of more than 4,000,000 kWh for the previous year

Variable Air Volume System – HVAC System that controls the dry-bulb temperature within a space by varying the volumetric flow of cooled supply air to the space

Variable Frequency Drive (VFD) or Adjustable Frequency Drive (AFD), Variable-Voltage/Variable-Frequency (VVVF) drive, Variable Speed Drive (VSD), AC drive, micro drive or inverter drive – a type of motor drive used in electro-mechanical drive systems to control AC motor speed and torque by varying motor input frequency and voltage [Wikipedia]

Ventilation – the process of supplying or removing air by natural or mechanical means to or from any space. Such air is not required to have been conditioned.

Visible Light Transmittance (VLT) – used to determine the amount of light transmitted through the glass

Water Heater – vessel in which water is heated and is withdrawn for use external to the system

Section III. Application and Exemption

3.1 Application

A. These guidelines are applicable to the design of:

1. New buildings and their systems with at least 112.5 kVA of total connected electrical loads or has at least 10,000 square meters (m²) Total Gross Floor Area (TGFA); and
2. Any expansion and/or modification of existing buildings or systems designed with total connected electrical loads of at least 112.5 kVA or with at least 10,000 square meters (m²) TGFA.

B. These guidelines shall not be used to circumvent any applicable safety, health or environmental requirements.

3.2 Exemptions

A. Areas with industrial/manufacturing processes

PART I

BUILDING ENVELOPE

Section IV. Thermal Performance of the Building Envelope

4.1 Scope

This section is mandatory for air-conditioned buildings. For non-air-conditioned buildings the requirements defined in this section are not mandatory, but recommendable to improve thermal comfort. The requirements and guidelines in this section cover external walls, roofs, air leakage and reflectance of the roof.

The thermal requirements shall apply only to air-conditioned buildings. The building envelope has to be designed to minimize external heat gain, and thereby reduce the cooling load of the air conditioning system.

The following describes two methodologies to fulfill building envelope requirements in regard to solar heat load and thermal transmittance: the flexible, but more complex Overall Thermal Transfer Value (OTTV) method, and the easier to apply prescriptive method.

4.2 OTTV Method

A. Approach

The solar heat gain through the building envelope constitutes a substantial share of heat load in a building, which shall have to be eventually absorbed by the air-conditioning system at the expense of energy input. To minimize solar heat gain, it is, therefore, the first consideration in the design of an energy-efficient building.

The architectural techniques used to achieve the said purpose are too numerous to mention. Siting and orientation of a rectangular building to avoid exposure of its long facades to face east and west, for instance, is a simple means to reduce solar heat gain, if the building site permits. Appropriate choice of building shape to minimize building envelope area and selection of light colors for wall finish to reflect solar radiation are other common-sense design alternatives to lower solar heat input.

The OTTV concept takes into consideration the three basic elements of heat gain through the external walls of a building, as follows:

- heat conduction through opaque walls;
- heat conduction through glass windows;
- solar radiation through the glass windows.

These three basic elements of heat input are averaged out over the whole envelope area of the building to give an overall thermal transfer value, or OTTV in short. This concept, in essence, helps to preserve a certain degree of flexibility in building design.

B. Facade

For the purpose of energy conservation, the maximum permissible OTTV has been set at

$$45\text{W/m}^2.$$

To calculate the OTTV of an external wall, use the basic formula below:

$$\text{OTTV} = \frac{(A_w \times U_w \times \text{TDeq}) + (A_f \times U_f \times \Delta T) + (A_f \times \text{SHGC} \times f \times \text{SF})}{A_o}$$

Where

- OTTV: overall thermal transfer (W/m^2)
 A_w : opaque wall area (m^2)
 U_w : thermal transmittance of opaque wall ($\text{W/m}^2\text{K}$)
 TDeq : equivalent temperature difference (K), see sub paragraph 1
 A_f : fenestration area (m^2)
 U_f : thermal transmittance of fenestration (W/m^2)
 ΔT : temperature difference (K) between exterior and interior, see sub paragraph 2
 f : SHGC correction factor f of shading device, see sub paragraph 3
 SHGC : solar heat gain coefficient of glazing, see sub paragraph 4
 SF : solar factor (W/m^2), see sub paragraph 5
 A_o : gross area of exterior wall (m^2) = $A_{vs} + A_f$

1. Equivalent Temperature Difference (TDeq)

Equivalent Temperature Difference (TDeq) is the temperature difference which results in the total heat flow through a structure as caused by the combined effects of solar radiation and outdoor temperature. The TDeq across a structure takes into account the types of construction (mass and density), degree of exposure, time of day, location and orientation of the construction and design condition.

For the purpose of simplicity in OTTV calculation, the TDeq of different types of construction have been narrowed down to three values according to the densities of the constructions, as given in *Table 1*.

Table 1: Equivalent Temperature Difference for Walls

Wall Construction Mass Per Unit Area	TDeq
0 – 125 kg/m ²	15 °K
126 – 195 kg/m ²	12 °K
Above 195 kg/m ²	10 °K

Source: *Guidelines on Energy Conserving Design of Buildings, 2007*

2. Temperature Difference between Exterior and Interior ΔT

The temperature difference between exterior and interior ΔT is the average annual temperature difference between the outside and inside of an air-conditioned building, and is required for calculation of the heat conduction through glazing. Contrary to the equivalent temperature difference T_{Deq} , ΔT does not consider solar radiation and is therefore with 5 K significantly lower.

3. Correction Factor for the Shading Device

The correction factor f is the ratio between the incoming solar radiation behind a shading device and the incoming solar radiation in front of a shading device and is therefore between 0 (opaque) and 1 (no shading). The correction factor can be derived from literature values, manufacturer data, simulation or calculation as shown in Subsection 4 on shading devices).

4. Solar Heat Gain Coefficient SHGC of Glazing

The solar heat gain coefficient is the ratio between the incoming solar radiation behind a glazing and the incoming solar radiation in front of a glazing. The solar heat gain coefficient can be derived from manufacturer data.

5. Solar Factor (SF)

The Solar Factor for vertical surfaces has been experimentally determined for this geographical zone. From data collected over a period of time for the eight primary orientations, the average Solar Factor for vertical surfaces has been worked out to be 130 W/m². This figure has to be modified by a correction factor when applied to a particular orientation, and also if the fenestration component is sloped at an angle skyward. For the purpose of the building regulations, any construction having a slope angle of more than 70° with respect to the horizontal shall be treated as a wall. For a given orientation and angle of slope, the Solar Factor is to be calculated from the following formula:

$$SF: 130 \times CF \text{ (W/m}^2\text{)}$$

Where CF is the correction factor with reference to the orientation of the façade and the pitch angle of the fenestration component and is given in *Table 2*.

Table 2: Solar Correction Factor Wall

Slope Angle	Orientation							
	N	NE	E	SE	S	SW	W	NW
70°	1.32	1.63	1.89	1.65	1.32	1.65	1.89	1.63
75°	1.17	1.48	1.75	1.50	1.18	1.50	1.75	1.48
80°	1.03	1.33	1.59	1.35	1.04	1.35	1.59	1.33
85°	0.87	1.17	1.42	1.19	0.89	1.19	1.42	1.17
90°	0.72	1.00	1.25	1.02	0.74	1.02	1.25	1.00

Source: *Guidelines on Energy Conserving Design of Buildings, 2007*

Note: The correction factors for other orientations and other pitch angles are found by interpolation.

As walls at different orientations receive different amounts of solar radiation, it is necessary in general to compute first the OTTVs of individual walls, then the OTTV of the whole building envelope. The latter is obtained by taking the weighted average of these values. To calculate for the envelope of the whole building, use the formula below:

$$OTTV = \frac{A_{01} \times OTTV_1 + A_{02} \times OTTV_2 + \dots + A_{0x} \times OTTV_x}{A_{01} + A_{02} + \dots + A_{0x}}$$

The gross area of an exterior wall shall include all opaque wall areas, window areas, and door areas, where such surfaces are exposed to outdoor air and enclose an air-conditioned space. The fenestration area shall include glazing, glazing bars, mullions, jambs, transoms, heads and sills of window construction and shall be measured from the extreme surfaces of the window construction.

Where more than one type of material and/or fenestration is used, the respective term or terms shall be expanded into sub-elements, such as:

$$(A_{w1} \times U_{w1} \times TDeq_1) + (A_{w2} \times U_{w2} \times TDeq_2), \text{ etc.}$$

In the case of a mixed-use building where the residential portion and the commercial portion are distinctly and physically separated from each other, e.g., in the form of a residential tower block and a commercial podium, the OTTVs of the two portions shall be separately computed.

C. Roof

For an air-conditioned building, solar heat gain through the roof also constitutes a substantial portion of the cooling load. From on-site solar radiation measurements taken, the intensity of the radiation on a horizontal surface can be as much as 3 times of that on a vertical surface.

The purpose of roof insulation is therefore two-folds: to conserve energy in air-conditioned buildings and to promote thermal comfort in non-air-conditioned buildings. In both cases, the building regulations require that the roof shall not have a thermal transmittance or U-value greater than the values tabulated in *Table 3*.

Table 3: Maximum U-value for Roof

Weight Group	Weight Range (Kg/m ²)	Maximum Thermal Transmittance (W/m ² K)	
		Air-conditioned Building	Non air-conditioned Building
light	under 50	0.5	0.8
medium	50 to 230	0.8	1.1
heavy	over 230	1.2	1.5

Source: Guidelines on Energy Conserving Design of Buildings, 2007

In the case of an air-conditioned building, the concept of OTTV is also applicable to its roof if the latter is provided with skylight. Otherwise, refer to the chapter with the prescriptive method. The OTTV concept for roofs takes into consideration three basic elements of heat gain, as follows:

- Heat conduction through opaque roof;
- Heat conduction through skylight;
- Solar radiation through skylight.

The maximum permissible OTTV for roofs is set at

45 W/m².

To calculate the OTTV of a roof, use the same basic OTTV formula for building façade described earlier.

For the purpose of simplicity in OTTV calculation, the TDeq of different types of roof constructions have been standardized in *Table 4*.

Table 4: Equivalent Temperature Difference for Roof

Wall Construction Mass Per Unit Area	TDeq
0 – 50 kg/m ²	24 °K
51 – 230 kg/m ²	20 °K
Over 230 kg/m ²	16 °K

Source: *Guidelines on Energy Conserving Design of Buildings, 2007*

Since a roof is more exposed to the sun than a facade, the following solar factor has to be applied for roofs:

SF: 320 x CF (W/m²)

Where CF is the correction factor with reference to the orientation of the roof and the pitch angle of the skylight component and is given in *Table 5*.

Table 5: Solar Correction Factor for Roof

Slope Angle	Orientation							
	N	NE	E	SE	S	SW	W	NW
0°	1.00	1.00	1.00	1.00	1.00	1.00	1.00	1.00
5°	1.00	1.01	1.02	1.02	1.00	1.02	1.02	1.01
10°	1.01	1.03	1.04	1.03	1.01	1.03	1.04	1.03
15°	1.01	1.03	1.05	1.03	1.01	1.03	1.05	1.03
20°	1.00	1.03	1.06	1.03	1.01	1.03	1.06	1.03
25°	0.98	1.02	1.06	1.03	0.99	1.03	1.06	1.02
30°	0.95	1.01	1.03	1.01	0.97	1.01	1.05	1.01
35°	0.93	0.98	1.03	0.99	0.94	0.99	1.03	0.98
40°	0.90	0.96	1.01	0.96	0.91	0.96	1.01	0.96
45°	.86	0.92	0.98	0.92	0.87	0.93	0.98	0.92
50°	0.81	0.89	0.95	0.89	0.83	0.89	0.95	0.89
55°	0.77	0.84	0.91	0.85	0.78	0.85	0.91	0.84
60°	0.71	0.85	0.86	0.80	0.73	0.80	0.86	0.79
65°	0.66	0.74	0.81	0.75	0.67	0.75	0.81	0.74

Source: *Guidelines on Energy Conserving Design of Buildings, 2007*

Note: See Appendix B to H for sample OTTV calculations, thermal conductivities, K-values, and glass thermal transmittance values.

4.3 Prescriptive Method

A. Solar Transmittance of Windows

Compared with wall assemblies, glazing transfers more heat, and hence, it is ideal to reduce the amount of glazing with respect to the wall in order to reduce internal heat gains.

The requirement of Window to Wall Ratio (WWR) needs to be balanced with the amount of daylight coming through the glazed area.

Solar Heat Gain Coefficient (SHGC) is used to determine the amount of solar heat admitted through the glass divided by the total solar radiation incident on the glass.

Visible Light Transmittance (VLT) is used to determine the amount of light transmitted through the glass.

WWR shall be balanced with SHGC_{adj} to maintain flexibility in design. To explain further, the higher the designed building WWR, the lower the required SHGC_{adj} in glass windows shall be and vice-versa. This does not, however, remove the option for building owners to apply windows with low SHGC_{adj} for building with low WWR. The size of the opening (with or without glass) shall be in accordance with the National Building Code (NBC).

For each WWR value, the SHGC_{adj} shall be in accordance with Table 6. The SHGC_{adj} requirement in Table 6 can be adjusted if sun breakers are provided in the windows. A sun breaker plays an important role in reducing solar heat gain as it stops solar radiation before it enters the building, and doing so reduces the cooling loads considerably. External shading has the additional positive effect of improving the internal comfort, cutting part of the direct radiation on occupants. This shall be applied only to shaded windows.

Table 6: SHGC_{adj} for Different Window to Wall Ratios (WWR)

WWR	Maximum SHGC _{adj}	Minimum VLT
10	0.80	0.80
20	0.70	0.70
30	0.60	0.70
40	0.45	0.60
50	0.44	0.55
60	0.37	0.50
70	0.31	0.45
80	0.27	0.40
90	0.24	0.35

Source: Prescribed Requirements, IFC Philippine Green Building Code Project, May 2013

SHGC_{adj} limits can be adjusted by multiplying it with the correction factors using the formula:

$$\text{SHGC}_{\text{adj}} = \text{SHGC} \times f$$

where

SHGC_{adj}: is the adjusted solar heat gain coefficient limit for windows with external shading

SHGC: is the solar heat gain coefficient of the glazing

f : is the SHGC correction factor f of the shading device. If there is no shading device, f can be set to 1.

SHGC is the solar heat gain coefficient of the glazing and can be derived from the manufacturer data. f is the SHGC correction factor f of the shading device and can be derived by the manufacturer data, simulation, or simplified calculation as described in the next subsection on shading devices.

B. Minimum Insulation Values

Insulation helps to reduce heat gain in a building, thus improving thermal comfort, acoustic quality, and reducing the load on the air conditioning system. Buildings shall be provided with roof insulation so that the average U-value is maximum $1.4 \text{ W/m}^2\text{K}$ and the average U-value of the wall is maximum $3.4 \text{ W/m}^2\text{K}$. Skylights shall have an opening ratio of maximum 5% related to the floor area of the room beneath.

4.4 Shading Devices and Determination of the Shading Coefficient

Shading devices, especially when installed externally, can help improve thermal comfort and significantly reduce energy consumption due to air conditioning in a building. The effectiveness of the shading device is defined by the correction factor f , which is the ratio of solar radiation behind and in front of a shading device. Hence $f = 1$ if there is a window without shading and $f = 0$ if the window is opaque.

Given the huge variety of shading devices, and hence f factors, take the following into account when determining the f factor:

1. manufacturer data
2. simulation
3. calculation

One of the most energy- and cost-efficient possibilities for external shading in tropical countries is the fixed overhang and vertical fin. To encourage the provision of sun-shading devices to improve thermal comfort and reduce energy demand, the building regulations make a special provision to relax the requirement pertaining to boundary clearance. Where overhangs, canopies, awnings, or other sun-shading devices are provided, these devices are permitted to project up to a point not less than 1600 mm from the lot boundary instead of the normal requirement of 2300 mm for boundary clearance.

To take advantage of this relaxation, the designer shall ensure that only non-combustible materials are used for the construction of the shading devices. It should be noted that the relaxation is only in respect to the projection of shading devices; wall designs shall still comply with the normal boundary clearance requirement.

To simplify the determination process, the f factor for these shading types can be calculated as follows:

First, the depth of the overhang or the vertical fin has to be calculated. Second, the height of the window (including the distance between the top part of the frame and the overhang), or the width of the window (including the distance between the frame and the fin), have to be calculated.

Figure 1: Schematic Representation of a Window and Related Horizontal Overhang or Vertical Fin

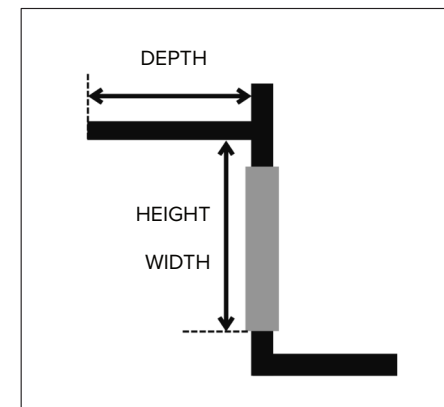

Based on the ratio between the depth of shading and the height/width of the window, the correction factor f can be selected from *Table 7*.

Table 7: Correction Factor f for External Fixed Shading

Depth/Height	SHGC Correction Factor f	
	Horizontal Shading	Vertical Shading
0.10	0.90	0.95
0.30	0.74	0.82
0.50	0.55	0.70
0.75	0.44	0.62
1.00	0.35	0.55

Source: Results of EU-ASEP simulation, 2020

4.5 Airtightness of the Building Envelope

The infiltration of warm air and moisture and exfiltration of cold air contribute substantially to the heat gain and energy consumption of an air-conditioned building. Also, warm and humid air can cause condensation in the building construction and subsequently lead to mold growth and health problems of the building occupants.

As a basic requirement, buildings shall not have unenclosed doorways, entrances, etc.; where heavy traffic of people is anticipated, self-closing doors shall be provided. The concept of an energy-efficient building is based on the assumption that the envelope of the building is completely enclosed to minimize the infiltration of warm air and exfiltration of cool air. Infiltration and exfiltration contribute substantially to the building's heat gain, as the warmer infiltrated air shall be cooled in order to maintain the desired comfort condition.

To further minimize the exfiltration of cool air and infiltration of warm air and moisture through leaky windows and doors, effective means of weather-stripping shall also be incorporated. Additionally, building envelope enclosures such as walls, roofs, and floors on grades shall be non-permeable to prevent the infiltration of moisture.

Preferably, doors and windows shall be designed to meet the following criteria when tested under a pressure differential of 75 Pa:

1. Windows: leakage to limit to 2.77 m³/h per meter of sash crack
2. Swinging revolving or sliding doors: leakage to limit to 61.2 m³/h per meter of door crack
3. Air curtains may be used in very high-volume entrances only when revolving or self-closing sliding doors and vestibules are not appropriate.
4. Entrance vestibules, airlocks, and anterooms shall have at least 3 meters depth/run before the next set of doors.
5. Entrances shall have auto door closers on air locks to keep cold air in and warm air out.

4.6 Reflectance of the Roof

A light-colored building envelope, especially the roof areas which are the most vulnerable, can reduce heat transfer from the outside to the inside of the building by having surfaces with high Solar Reflectance Index (SRI).

Roofs shall have one or a combination of the following measures:

1. Roof color with a minimum average SRI of 70
2. More than 70 % of the roof is back ventilated.
3. More than 70 % of the roof is covered by solar thermal and/or PV.
4. More than 70% is covered by a green roof.

4.7 Required Design Documentation

The following documents shall be required for the building permit application:

- A. Architectural drawings:
 - Floor plans with the supporting details and information to satisfy the requirements of this section
 - Elevations with the supporting details and information to satisfy the requirements of this section
 - Sectional drawings with the supporting details and information to satisfy the requirements of this section
- B. Material specifications, e.g. in tender documents or detailed drawings:
 - Windows, skylights: U-value, SHGC value
 - Walls: material type, thickness, k-values
 - Roofs: material type, thickness, k-values
 - Shading: shading length, f-value
 - Insulation specifications supporting wall and roof k-values
 - Roof deck, wall, and floor specification on non-permeable coating
- C. Proof/Evidence of building envelope compliance
 - OTTV method: OTTV calculation for wall and roof
 - Prescriptive method: calculation of window-to-wall ratio
 - SHGC of glass window to be used
 - Proposed Roof U-value computation
 - Proposed Wall U-value computation
 - Skylight area and roof area computations
 - Proposed methods and materials for building airtightness
 - Proposed SRI of the roof

PART II MECHANICAL SYSTEMS

Section V. Air Conditioning and Ventilating System

5.1 Scope

The requirements in this section represent minimum design criteria. Designers shall evaluate other energy conservation measures, which may be applicable to the proposed building or the proposed building renovations. The Philippine Green Building Code (PGBC) applies to all new construction and/or alteration of buildings with a Total Gross Floor Area (TGFA) of 10,000 square meters (m²) or more. In case of conflict between the provisions of the PGBC and these guidelines, the most stringent requirement shall apply.

Building owners with buildings with a TGFA of 10,000 m² or more shall be required to submit the building's annual electricity usage (kWh/year), fuel consumption (liters/year) of generators, and liquefied petroleum gas (LPG) consumption (kg/year). This shall be submitted in the application for the renewal of mechanical systems. Documents to be submitted in the report shall be the monthly electrical bills, fuel, and LPG delivery receipts.

5.2 Load Calculation

A. Calculation Procedures

Cooling system design loads for the purpose of sizing the system and equipment shall be determined in accordance with the procedures in the latest edition of the ASHRAE Handbook of Fundamentals or other equivalent publications.

B. Indoor Design Conditions

The indoor conditions in an air-conditioned space shall conform to the following:

- | | |
|---------------------------------|------|
| 1. Design Dry Bulb Temperature | 25°C |
| 2. Design Relative Humidity | 55% |
| 3. Maximum Dry Bulb Temperature | 27°C |
| 4. Minimum Dry Bulb Temperature | 23°C |
| 5. Maximum Relative Humidity | 60% |
| 6. Minimum Relative Humidity | 50% |

Note: Indoor design conditions may differ from those presented above because of special occupancy or process requirement, source control, air contamination, or local regulation.

C. Outdoor Design Conditions

The outdoor conditions shall be taken as follows for Climate Zone 0A:

- | | |
|--------------------------------|------|
| 1. Design Dry Bulb Temperature | 35°C |
| 2. Design Wet Bulb Temperature | 28°C |

Note: See ASHRAE Standard 169-2013, Philippine Stations and Climate Zones on Appendix O.

D. Ventilation

The quality and quantity of air used to ventilate air-conditioned spaces shall always be sufficient and acceptable to human occupation and comply with applicable health and/or air quality requirements. Ventilation requirements shall conform to the design criteria in Table 15.

Exception: Outdoor air qualities may exceed those shown in Table 16 because of special occupancy or process requirements, source control air contamination or local regulations.

E. Kitchen Ventilation

Figures 4 through 9 show the six basic hood styles for Type 1 applications. The style names are not used universally in all standards and codes but are well accepted in the industry. The styles are as follows:

1. Wall-mounted canopy – used for all types of cooking equipment located against the wall (See Figure 4)
2. Single-island canopy – used for all types of cooking equipment in a single-line island configuration (See Figure 5)
3. Double-island canopy – used for all types of cooking equipment mounted back to back in an island configuration (See Figure 6)
4. Back shelf – used for counter-height equipment typically located against the wall, but could be freestanding. (See Figure 7)
5. Eyebrow – used for direct mounting to oven and some dishwashers (See Figure 8)
6. Pass-over – used over counter-height equipment when pass-over configuration (from the cooking side to the serving side) is required (See Figure 9)

5.3 System Design and Sizing

Air conditioning system and equipment shall be sized as close as possible to the space and system loads calculated in accordance with the subsection on load calculation. The design of the system and the associated equipment and controls shall take into account important factors such as nature of application, type of building construction, indoor and outdoor conditions, internal load patterns, control methods for efficient use, and economic factors.

- A. Engineered systems and equipment shall be properly sized and selected to meet maximum loads and shall have good unloading characteristics to meet the minimum load efficiency. These shall be arranged in multiple units or increments of capacity to meet partial and minimum load requirements without short cycling.

Table 8: Number of Chillers and Water Chiller Types

Total Chiller Plant Capacity	Number of Chillers	
≤300 tons	One	
>300, <600 tons	Two sized equally	
≥600 tons	Two minimum with chillers added so that no chiller is larger than 800 tons, all sized equally	
Individual Chiller Plant Capacity	Electric Chiller Type	Fossil Fuel Chiller Type
≤100 tons	Scroll	Single-effect absorption, direct fired
>100 tons, <600	Screw	Double-effect absorption, direct fired
>600	Centrifugal	Double-effect absorption, direct fired

Source: ASHRAE 90.1-2019

General Notes for Number of Chillers: If the total capacity of the chilled water requirement is over 2,400 TR (8,450 kW), the sizing would be at the discretion of the designer. VFD drive would only be required for units that would be doing peaking loads. Baseload chillers would be soft-starter drive.

Table 9: Energy Utilization Index Comparison

Energy utilization index comparison (kWh/SqM-Yr)				
Building Use	IFC-PGBI Survey 2013	EDGE Philippines Baseline	Philippine GB Code Min. Compliance (EDGE Calc)	ZERO Code (derived from ASHRAE 90.1-2016 Min. Compliance)
Office	345	136	98	98
Residential Condo	65	65	43	136
Hospital	338	367	263	375
Hotel	174	342	234	230
School	131	75	47	132
Retail (Mall)	336	200	151	145

Source: IFC/Green Building Code Survey

Table 10: Building Performance Factor

Building Area Type	Climate Zone																
	0A and 1A	0B and 1B	2A	2B	3A	3B	3C	4A	4B	4C	5A	5B	5C	6A	6B	7	8
Multifamily	0.68	0.70	0.66	0.66	0.69	0.68	0.59	0.74	0.76	0.74	0.70	0.73	0.75	0.68	0.71	0.68	0.72
Healthcare/hospital	0.60	0.60	0.58	0.54	0.56	0.55	0.55	0.55	0.54	0.54	0.57	0.52	0.54	0.57	0.52	0.57	0.57
Hotel/motel	0.55	0.53	0.53	0.52	0.53	0.54	0.54	0.53	0.53	0.52	0.50	0.51	0.51	0.50	0.51	0.50	0.50
Office	0.52	0.57	0.50	0.56	0.53	0.56	0.48	0.51	0.52	0.49	0.51	0.51	0.49	0.52	0.51	0.49	0.51
Restaurant	0.63	0.64	0.60	0.60	0.60	0.61	0.58	0.62	0.57	0.61	0.63	0.60	0.64	0.65	0.62	0.67	0.70
Retail	0.51	0.54	0.49	0.55	0.51	0.55	0.53	0.51	0.55	0.54	0.50	0.54	0.55	0.50	0.51	0.48	0.50
School	0.39	0.47	0.38	0.43	0.38	0.42	0.40	0.37	0.40	0.38	0.38	0.40	0.36	0.36	0.37	0.36	0.37
Warehouse	0.38	0.42	0.40	0.42	0.43	0.44	0.43	0.44	0.43	0.46	0.49	0.47	0.48	0.54	0.51	0.57	0.57
All others	0.56	0.57	0.50	0.52	0.50	0.54	0.53	0.53	0.52	0.54	0.51	0.51	0.50	0.50	0.50	0.50	0.46

Source: ASHRAE 90.1-2019

- B. Considerations shall be given at the design stage for providing centralized monitoring and control to achieve optimum operations with minimum energy consumption.

5.4 Fan System Design Criteria

A. General

The following design criteria apply to all air conditioning fan systems used for comfort ventilating and/or air conditioning. For the purpose of this section, the energy demand of a fan system is the sum of the demand of all fans required to operate at design conditions to supply air from the cooling source to the conditioned space(s), or exhaust it to the outdoors.

Exception: System with a total fan motor power requirement of 5 kW or less.

B. Constant Volume Fan Systems

For fan systems that provide a constant air volume whenever the fans are operating, the power required by the motor of the combined fan system at design conditions shall not exceed 0.5 W/m³/h.

C. Variable Air Volume (VAV) Fan Systems

1. For fan systems that are able to vary system air volume automatically as a function of load, the power required by the motor of the combined fan system at design conditions shall not exceed 0.5 W/m³/h.
2. Individual VAV fans with motor rated at 5 kW and larger shall include control and devices such as a variable speed drive necessary to make the fan motor operate efficiently even at flow rates of as low as 40% of the rated flow. Electronically commutated (EC) motors shall be used.

5.5 Pumping System Design Criteria

A. General

The following design criteria apply to all pumping systems used for comfort air conditioning. For the purpose of this section, the energy demand of a pumping system is the sum of the demand of all pumps required to operate at design conditions to supply fluid from the cooling source to the conditioned space(s) and return it back to the source. Pumps doing the peaking load shall have VFD drives.

Exception: System with total pump motor requirement of 5 kW or less

B. Pressure Drop

Chilled water and cooling water circuits of air conditioning systems shall be designed at a maximum velocity of 1.2 m/s (3.9 fps) for a 50 mm diameter pipe and pressure drop limit of 39.2 kPa per 100 (4 ft/100 ft) equivalent meter for piping over 50 mm diameter. To minimize erosion for the attainment of the piping system, the water velocities found in *Table 19* shall not be exceeded.

Table 11: Piping System Design Maximum Flow Rate in Gallons Per Minute (GPM)

Operating Hours/Year	≤2000 Hours/Year		≥2000 and ≤4400 Hours/Year		≥4000/Year		
	Normal Pipe Size, In.	Other	Variable Flow/ Variable Speed	Other	Variable Flow/ Variable Speed	Other	Variable Flow/ Variable Speed
2 1/2		120	180	85	130	68	110
3		180	270	140	210	110	170
4		350	530	260	400	210	320
5		410	620	310	470	250	370
6		740	1100	570	860	440	680
8		1200	1800	900	1400	700	1100
10		1800	2700	1300	2000	1000	1600
12		2500	3800	1900	2900	1500	2300
Maximum velocity for pipes over 14 to 24 in. in size		8.5 ft/s	13.0 ft/s	6.5ft/s	9.5ft/s	5.0ft/s	7.5ft/s

Source: ASHRAE Standard 90.1-2019

C. Variable Flow

Pumping systems that are provided with control valves designed to modulate or step open or close, depending on the load, shall be required for variable fluid flow. The system shall be capable of reducing system flow to 50% of design flow or less.

Flow may be varied using variable speed-driven pumps, multiple stage pumps, or pumps riding their performance characteristic curves. Pumps with steep performance curves shall not be used since they tend to limit flow rates. Variable speed or staged pumping shall be employed in large pumping systems.

Exceptions:

- System where a minimum flow greater than 50% of the design flow rate is required for the proper operation of the equipment served by the system
- Systems that serve only one control valve

5.6 Air Distribution System Design Criteria

A. General

The temperature and humidity of the air within the conditioned space shall be maintained at an air movement from 0.20 to 0.30 m/s (39 fpm to 59 fpm).

The air in such conditioned space(s) shall at all times be in constant motion sufficient to maintain a reasonable uniformity of temperature and humidity but shall not cause objectionable draft in any occupied portion(s). In cases where the only source of air contamination is the occupant, air movement shall have a velocity of not more than 0.25 m/s (49.2 fpm) as the air enters the space.

5.7 Controls

A. System Control

1. Each air-conditioned system shall be provided with at least one control device for temperature regulation.

2. All mechanical ventilating system (supply and exhaust) equipment, either continuously operating or not, shall be provided with readily accessible manual and/or automatic controls or other means of volume reduction, or shut-off when ventilation is not required.

B. Zone Control

1. Each air-conditioned zone shall be controlled by individual thermostatic controls responding to temperature within the zone.
2. Systems that serve zones that can be expected to operate non-simultaneously for more than 750 hours per year (i.e. approximately 3 hours per day on a 5-day week basis) shall include isolation devices and controls to shut off the supply of conditioned air to each zone independently.

Isolation is not required for:

- 4.a Zones expected to operate continuously
- 4.b Systems which are restricted by process requirements
- 4.c Gravity and other non-electrical ventilating systems that may be controlled by readily accessible manual dampers.

C. Control Area

- C.1 The supply of conditioned air to each zone/area shall be controlled by an individual control device responding to the average temperature within the zone. Each controlled zone shall not exceed 465 m² in area.
- C.2 For buildings where occupancy patterns are not known at the time of the system design, such as speculative buildings, isolation areas may be pre-designed.

C.3 Zones may be grouped into a single isolation area, provided the total conditioned floor area does not exceed 465 m² per group, or includes more than one floor.

D. Temperature Controls

Where used to control comfort cooling, temperature controllers shall be capable of being set locally or remotely by adjustment or selection of the sensors, between 23°C and 27°C, or in accordance with local regulation.

E. Thermostat

Location of the thermostats in controlled zones shall measure a condition representing the whole space and shall not be affected by direct radiation, drafts, or abnormal thermal conduction or stratification.

F. Building Automation System

Buildings with an air-conditioning system with a capacity of 1053 kW (300 TR) or larger shall be provided with building automation systems with software that will optimize, monitor, and control mechanical and electrical equipment with complete data-logging of its operational performance and maintenance schedule.

G. Germicidal Irradiation and Filtration System for AHUs and FCUs

A germicidal irradiation filtration system is needed for air handling units (AHUs) and fan coil units (FCUs) for efficient disinfection. A High Efficiency Particulate Air (HEPA) filter or Minimum Efficiency Reporting Value (MERV)13 filter and above would increase the static pressure of the equipment blower; thus, increasing the blower horsepower is needed to operate the AHU and FCU. With ultraviolet germicidal irradiation (UVGI) and MERV 6 filters, the increase in blower horsepower is no longer necessary; hence, the current blower can still be used.

5.8 Chiller Plant Insulation

- A. All chilled water piping shall be thermally insulated in accordance with *Table 20* to prevent heat gain and avoid sweating on the insulation surface. The insulation will be suitably protected from damage.
- B. The chiller surface, especially the evaporator shell and compressor suction line(s), shall be insulated to prevent sweating and heat gain. Insulation covering surfaces on which moisture can condense, or those exposed to ambient conditions, shall be vapor-sealed to prevent any moisture seepage through the insulation, or to prevent condensation in the insulation.

Exceptions:

1. Piping that conveys fluids that have not been cooled through the use of fossil fuels or electricity
2. Piping at fluid temperatures between 20°C and 40°C
3. When the heat gain of the piping without insulation does not increase the energy requirements of the building

- C. For materials with thermal resistance greater than 0.032 m² °C/W-mm, the minimum insulation thickness shall be as follows:

$$\frac{0.032 \times \text{thickness in Table 20}}{t = \text{actual R value}}$$

t = actual R value

Where :

t = minimum thickness in mm

R = actual thermal resistance, m² °C/W-mm

- D. For materials with thermal resistance lower than 0.028 m² °C/W-mm, the minimum insulation thickness shall be:

$$\frac{0.028 \times \text{thickness in Table 20}}{t = \text{actual R value}}$$

t = actual R value

Where :

t = minimum thickness in mm

R = actual thermal resistance, m²°C/W-mm

5.9 Air Handling System Insulation

- A. All air handling ducts and plenums installed as part of the air distribution system and which are outside of air-conditioned spaces shall be thermally insulated sufficiently to minimize temperature rise of the air stream within them, and to prevent surface condensation. Insulated ducts located outside of buildings shall be jacketed for rain tightness and for protection against damage. Air ducts or plenums within air-conditioned spaces may not be insulated if the temperature difference (TD) between the air outside and within the ducts or plenum would not cause surface condensation. Due consideration shall be made to the dew point temperature of the air surrounding the ducts or plenums.

The required insulation thickness shall be computed using insulation material having resistivity ranging from 0.023 to 0.056 m². °C/W-mm and the following equation:

$$L = \frac{kR_s (D_p - t_o)}{(D_b - D_p)}$$

Where:

- Db = ambient still air-dry bulb temperature, °C
- Dp = dew point, °C
- To = operating temperature, °C
- Rs = surface thermal resistance = 0.115 m² °C/W-mm
- k = mean thermal conductivity, W-mm/m²°C
- L = thickness, mm

Exceptions:

1. When the heat gain of the ducts, without insulations, shall not increase the energy requirements of the building
2. Exhaust air ducts

- B. The thermal resistance of the insulation, excluding film resistance, shall be:

$$\frac{TD}{347} = m^2°C/W-mm$$

Where:

TD = temperature differential in °C

5.10 Air Conditioning Equipment

A. Minimum Equipment Performance

Air conditioning equipment shall have a minimum performance corresponding to the rated conditions shown in *Table 21*. Data furnished by equipment suppliers or manufacturers certified under a nationally recognized certification program or rating procedure shall be acceptable to satisfy these requirements.

1. Performance Rating

The performance rating of the air conditioning equipment with cooling capacity up to 50,000 kJ/hr (47,391 BTU/hr) or 14 kW (3.95 TR) shall be measured through the Cooling Seasonal Performance Factor (CSPF).

The CSPF shall not be less than those quoted in the two-star range in the current Energy Efficiency Performance Rating for Room Air Conditioners table (see *Table 12*) in Annex D.1 – Particular Product Requirements: Air Conditioners of the DOE's Philippine Energy Labeling Program.

Table 12: Energy Efficiency Performance Rating for Room Air Conditioners (2020)

Cooling Seasonal Performance Factor (CSPF)			
EEPR	Below 3.33kW	3.33kW to 9.99kW	10.0kW to 14kW
One Star	3.08 to 3.31	2.81 to 3.11	≤ 3.11
Two Star	3.32 to 3.55	3.12 to 3.42	3.12 to 3.42
Three Star	3.56 to 3.79	3.43 to 3.73	3.43 to 3.73
Four Star	3.80 to 4.00	3.74 to 4.00	3.74 to 4.00
Five Star	≥ 4.01	≥ 4.01	≥ 4.01

Source: Annex D.1 – Particular Product Requirements: Air Conditioners, DOE Department Circular No.: DC 2020-06-0015

2. Performance Rating

The performance rating of the air conditioning equipment above 14 kW (3.95 TR) shall be measured by its EER or kWe/TR, whichever is applicable.

The EER shall not be less than those quoted in Table 22, while kWe/TR shall not be greater than the figures in the same table.

a. Field-Assembled Equipment and Components

When components from more than one supplier are used as parts of the air conditioning system, component efficiencies shall be specified based on the data provided by the suppliers/manufacturers, which shall provide a system that complies with the requirements of the subsection on Minimum Equipment Performance.

b. Air Conditioning Equipment Controls

Air conditioning equipment shall have a means of controlling its capacity based on load requirement.

5.11 Heat Recovery

Whenever there is a big demand for hot water requirement and if economical, heat recovery shall be adopted in the air conditioning system condenser heat. Another would be using Enthalpy Recovery of Exhaust Air or Energy Recovery Ventilation for exhaust air.

A. Enthalpy of exhaust air

All buildings with centralized air supply system shall use enthalpy recovery wheel or energy recovery ventilation with efficiency of at least 60% of 90% exhaust air. When buildings have outside air or fresh air supply and they extract air through mechanical means, heat exchangers can use the air extracted from the building area to pre-condition the incoming outdoor air. This process takes into account the fact that the extracted air is usually already conditioned, and therefore colder and drier.

Enthalpy recovery is the process of recovering some energy from the building exhaust air stream to pre-condition the fresh air intake.

Figure 2: Circulation of Outdoor and Indoor Air in an Enthalpy (Energy) Recovery Ventilation

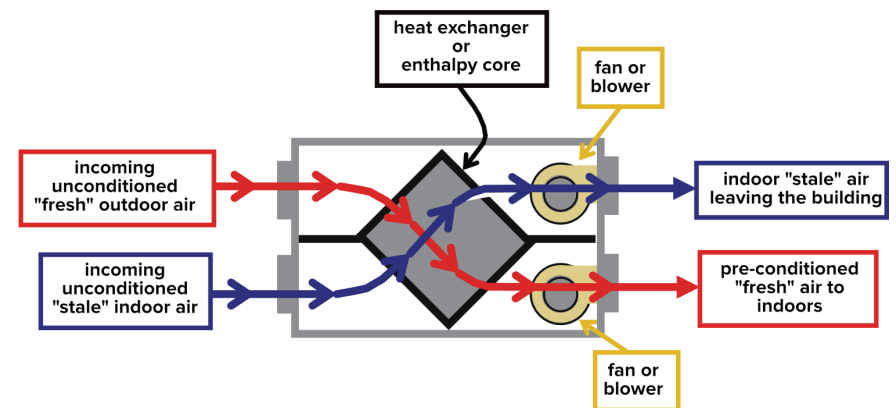
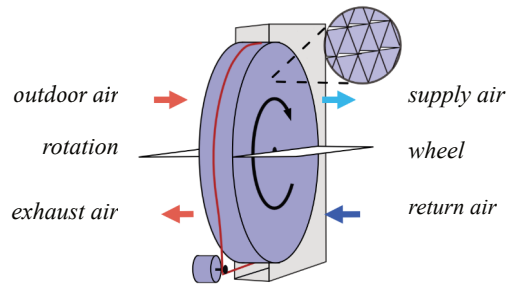

Figure 3: Enthalpy or Heat Recovery Wheel



5.12 Thermal Comfort in Non-Air-Conditioned Buildings

A. General Principles of Thermal Comfort

The main variables that affect human comfort are as follows:

1. dry bulb temperature
2. relative humidity or wet bulb temperature
3. air movement
4. ventilation
5. thermal radiation from hot surface (ceiling, walls, and glass windows).

To a lesser extent, certain other factors also affect human comfort like indoor air quality.

B. When cross ventilation in a room is assured, the relationship between ventilation rate and design wind speed is governed by the following equation:

$$Q = 17 C_eVA$$

Where:

- Q = ventilation rate in m³/min
- C_e = effectiveness of opening (C_e is assumed to be 0.5 to 0.6 for perpendicular winds and 0.25 to 0.35 for diagonal winds)
- V = design wind speed in km/h
- A = area of opening in m²

1. The design wind speed for a particular type of structure, locality, and orientation has to be duly corrected to allow for height and screening effects of other buildings. The coefficient of discharge C_e is found to decrease fairly rapidly with an increase in the distance between the two openings in series, i.e., with an increase in room width. At 5.5 m, it will level off to about 0.47. In the equation of ventilation rate, C_e is used to modify the external wind speed.

To determine the wind velocity near a building, the wind available at the time and height of the building, as well as the velocity gradient due to the ground friction, shall be considered.

A general equation, known as the “Power Law” is given by the Equation:

$$V_z = V_g \frac{(Z)^a}{Z_g}$$

Where:

- V_z = velocity at height z, m/s
- V_g = gradient velocity, m/s
- Z = height, m
- Z_g = gradient height, m
- A = a power index as given in the following table

Table 13: Values of “a”

Type of Country	Z _g (meter)	a
Open country	274	0.16
Moderately rough, wooded country, small town	396	0.28
Rough, center of large town	518	0.40

Source: Guidelines on Energy Conserving Design of Buildings, 2007

2. Natural Ventilation by Jack Roof and Roof Ventilator

- a. The performance of roof ventilators is normally rated in terms of speed and indoor and outdoor temperature differential to take into account the two natural motive forces of ventilation: thermal force and wind effect. The performance for roof cowls can be rated in the simplified equations as follows:

$$Q = 208 AV$$

Where:

Q = ventilation rate (m³/h)

A = throat area of ventilator (cm²)

V = wind speed (km/h)

- b. A jack roof has poorer ventilation performance. However, assuming that a jack roof is about 50% as efficient as a cowl ventilator since the windward side of a jack roof does not act as an exhaust opening, the net area of jack roofs required per meter run of a building is about 1.2 m² for a building width of 18 m.
- c. The intake fresh air louver shall be at 1 meter above the floor so that the fresh air with lower temperature pushes up the hot air up to the roof ventilator/jack roof ventilator.

C. Provision for Natural Ventilation and Lighting

Note: The requirements below are subject to compliance with the provisions of Easement of Light and View of the Civil Code of the Philippines, specifically Articles 667 to 673.

1. In natural regulations, it is specified that every building shall have:
 - a) natural lighting through windows, skylights, fanlights, doors, and other approved natural light transmitting media; and
 - b) natural ventilation through windows, skylights, fanlights, doors, louvers or similar ventilation openings.

2. In general, openings facing the sky, street courtyard, or air well shall be considered as acceptable sources of natural lighting and ventilation.
3. In the case of a building other than a factory or warehouse, any part of the building within 9 m from an acceptable opening is considered adequately ventilated by natural means.
4. In the case of a factory or warehouse, the maximum effective coverage of any window and other openings on an external wall is 12 m from the opening, whereas the coverage of any jack roof or other openings on the roof is 9 m, measured horizontally from the opening.
5. In addition, every room in any building shall have natural lighting and ventilation through one or more sources having an aggregate of not less than x percent of the floor space of the room, of which at least y percent shall have an opening to allow free uninterrupted passage of air. The respective values of x and y are given in *Table 23* according to the types of occupancy or types of usage of the room.
6. In the case of public garages, two or more sides of the garage shall have an opening for cross ventilation and the area opening will be at least 50% of the area of the wall where it is located.
7. Enclosed parking garage ventilation systems shall automatically detect contaminant levels by using supervisory control and data acquisition (SCADA) of building management systems (BMS); this is a must for energy efficiency. An induction (jet fan) ventilation with an electronically commutated (EC) motor shall be used in basement parking garages due to the following:
 - a. Effective dilution of contaminants within the car park environment as compared with the ducted system
 - b. The car park is too large and too deep to ventilate naturally.
 - c. Slab penetrations can be reduced. No need for ventilation plant rooms.

- d. Capital cost savings can be found through reduced car park height and less site excavation, less concrete and steel.
- 8. For terrace houses having a depth greater than 12m, permanent ventilation from front to rear shall be provided to facilitate cross ventilation by suitable vents in all front, back and cross walls at each floor. Such vents shall have a net opening area of not less than 0.4 m² each.

D. Mechanical Ventilation

- 1. Where site conditions dictate that the normal requirements for natural lighting and ventilation cannot be met, the building regulations may allow the use of mechanical ventilation as substitute.
- 2. According to the regulations, the quantity of fresh air supply for mechanical ventilation of any room or space in a building shall be in accordance with the specified rates in *Table 24*.

Unless justified by exceptional circumstances, the ventilation rate shall not be exceeded by more than 30%.

Table 14: Air Intake Minimum Separation Distance

Object	Minimum Distance, ft. (m)
Class 2 air exhaust/relief outlet	10 (3)
Class 3 air exhaust/relief outlet	15 (5)
Class 4 air exhaust/relief outlet	30 (10)
Cooling tower exhaust	25 (7.5)
Cooling tower intake or basin	15 (5)
Driveway, street, or parking place	5 (1.5)
Garage entry, automobile loading area, or drive-in queue	15 (5)
Garbage storage/pick-up area, dumpsters	15 (5)
Plumbing vents terminating at least 3 ft (1 m) above the level of the outdoor air intake	3 (1)
Plumbing vents terminating less than 3 ft (1 m) above the level of the outdoor intake	10 (3)
Roof, landscaped grade, or other surface directly below intake	1 (0.30)
Thoroughfare with high traffic volume	25 (7.5)
Truck loading area or dock, bus parking idling area	25 (7.5)
Vents, chimneys, and fixes from combustion appliances and equipment	15 (5)

Source: ASHRAE 62.1-2019

Figure 4: Wall Mounted Canopy

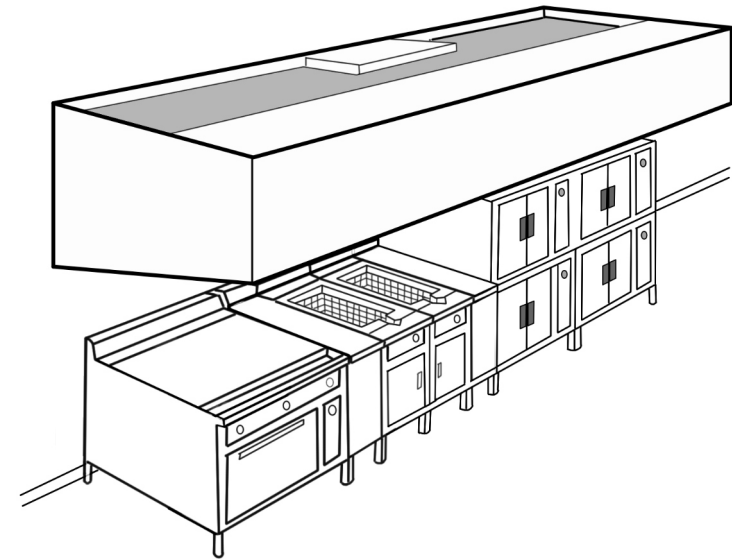

Figure 5: Single Island Canopy

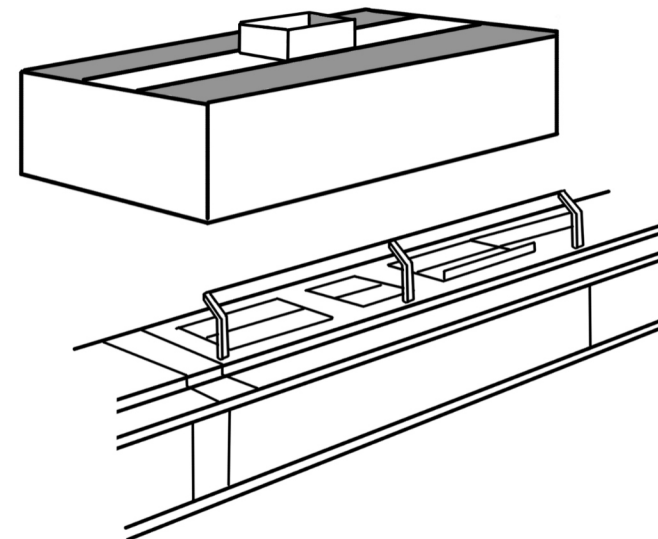

Figure 6: Double Island Canopy

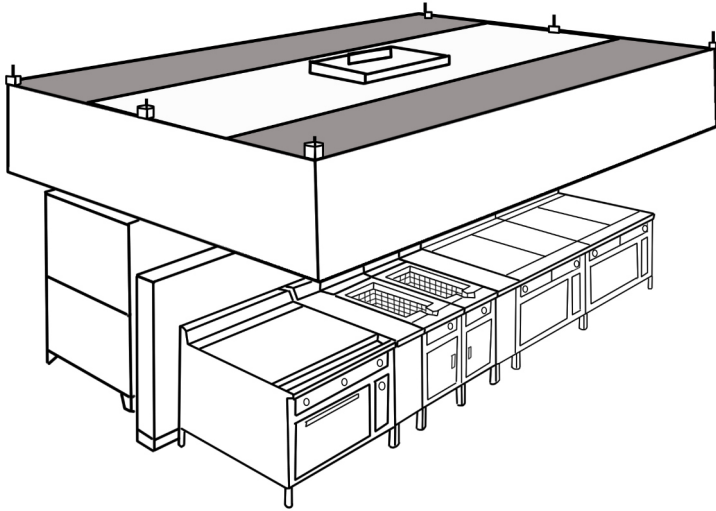

Figure 8: Eyebrow

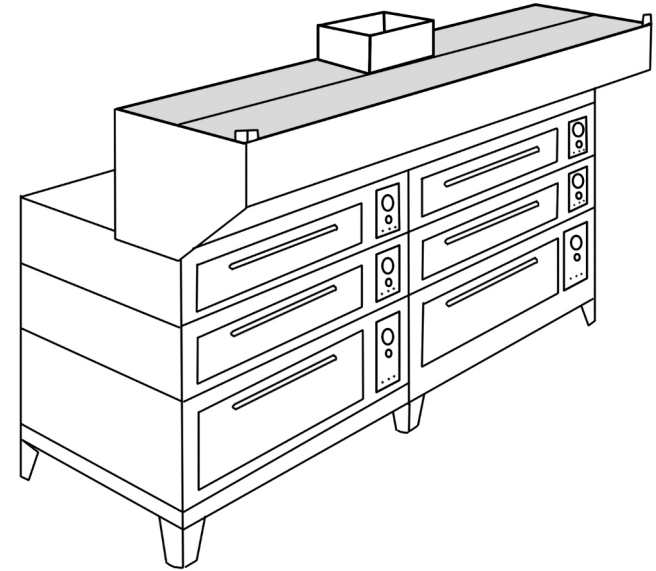

Figure 7: Back Shelf Canopy

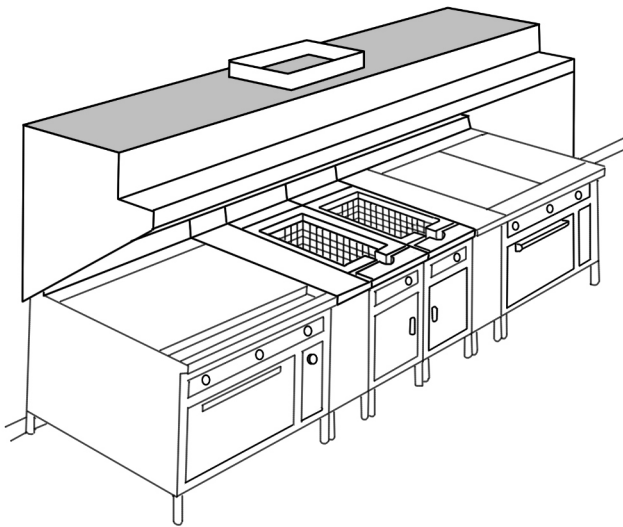

Figure 9: Pass-over

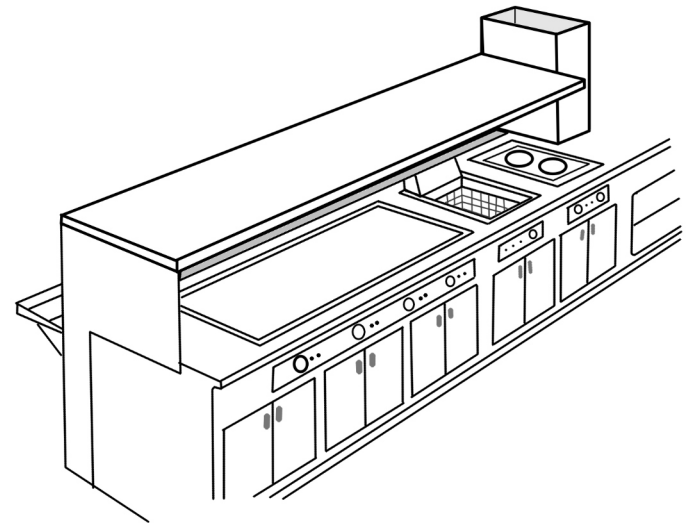

Table 15: Minimum Ventilation Rates in Breathing Zone

Occupancy Category	People Outdoor Air Rate R_p		Area Outdoor Air Rate R_p		Default Values	Air Class	OS (6.26.1.4)
	Cfm/person	L/s* person	Cfm/ft ²	L/s* m ²	Occupant Density		
					#1000 ft ² or 100 m ²		
Animal Facilities							
Animal Exam Room (veterinary ofc)	10	5	0.12	0.6	20	2	
Animal Imaging (MRVCT/PET)	10	5	0.18	0.9	20	3	
Animal operating rooms	10	5	0.18	0.9	20	3	
Animal postoperative recovery rooms	10	5	0.18	0.9	20	3	
Animal preparation rooms	10	5	0.18	0.9	20	3	
Animal procedure room	10	5	0.18	0.9	20	3	
Animal surgery scrub	10	5	0.18	0.9	20	3	
Large-animal holding room	10	5	0.18	0.9	20	3	
Necropsy	10	5	0.18	0.9	20	3	
Small-animal-cage room (static cages)	10	5	0.18	0.9	20	3	
Small-animal-cage room (ventilated cages)	10	5	0.18	0.9	20	3	
Correctional Facilities							
Booking/waiting	7.5	3.8	0.06	0.3	50	2	
Cell	5	2.5	0.12	0.6	25	2	
Dayroom	5	2.5	0.06	0.3	30	1	
Guard Stations	5	2.5	0.06	0.3	15	1	
Education Facilities							
Art Classroom	10	5	0.18	0.9	20	2	
Classroom (ages 5 to 8)	10	5	0.12	0.6	25	1	
Classroom (ages 9 plus)	10	5	0.12	0.6	35	1	
Computer lab	10	5	0.12	0.6	25	1	
Daycare sickroom	10	5	0.18	0.9	25	3	
Daycare (through age 4)	10	5	0.18	0.9	25	2	
Lecture Classroom	10	5	0.06	0.3	65	1	✓
Lecture hall (fixed seats)	7.5	3.8	0.06	0.3	150	1	✓
Libraries	5	2.5	0.12	0.6	10		
Media Center	10	5	0.12	0.6	25	1	
Multiuse assembly	7.5	3.8	0.06	0.3	100	1	✓
Music theater/dance	10	5	0.06	0.3	35	1	✓
Science laboratories	10	5	0.18	0.9	25	2	

Source: ASHRAE 62.1-2019

Table 15 (Continued)

Occupancy Category	People Outdoor Air Rate R_p		Area Outdoor Air Rate R_p		Default Values	Air Class	OS (6.26.1.4)
	Cfm/person	L/s* person	Cfm/ft ²	L/s* m ²	Occupant Density		
					#1000 ft ² or 100 m ²		
Education Facilities							
University/college laboratories	10	5	0.18	0.9	25	2	
Wood metal shop	10	5	0.18	0.9	20	2	
Food and beverage service							
Bars, cocktails, lounges	7.5	3.8	0.18	0.9	100	2	
Cafeteria, fastfood, dining	7.5	3.8	0.18	0.9	100	2	
Kitchen (cooking)	7.5	3.8	0.12	0.6	20	2	
Restaurant, dining rooms	7.5	3.8	0.18	0.9	70	2	
Food and beverage service, General							
Break rooms	5	2.5	0.06	0.3	25	1	✓
Coffee stations	5	2.5	0.06	0.3	20	1	✓
Conference/meetings	5	2.5	0.06	0.3	50	1	✓
Corridors	--	--	0.06	0.3	--	1	✓
Occupiable storage rooms for liquids or gels	5	2.5	0.12	0.6	2	2	
Hotels, Motels, Resort, Dormitories							
Barracks sleeping areas	5	2.5	0.06	0.3	20	1	✓
Bedroom/living room	5	2.5	0.06	0.3	10	1	✓
Laundry rooms, central	5	2.5	0.12	0.6	10	2	
Laundry rooms within dwelling units	5	2.5	0.12	0.6	10	1	
Lobbies/prefunction	7.5	3.8	0.06	0.3	30	1	✓
Multipurpose assembly	5	2.5	0.06	0.3	120	1	✓
Miscellaneous Spaces							
Banks or banks lobbies	7.5	3.8	0.06	0.3	15	1	✓
Bank vaults/safe deposit	5	2.5	0.06	0.3	5	2	✓
Computer (not printing)	5	2.5	0.06	0.3	4	1	✓
Freezer and refrigerated spaces (<50°F, 10°C)	10	5	0	0	0	2	
Manufacturing where hazardous materials are not used	10	5	0.18	0.9	7	2	
Manufacturing where hazardous materials are used (excludes heavy industrial and chemical processes)	10	5	0.18	0.9	7	3	
Pharmacy (prep. area)	5	2.5	0.18	0.9	10	2	
Photo studios	5	2.5	0.12	0.6	10	2	
Shipping/receiving	10	5	0.12	0.6	2	2	

Source: ASHRAE 62.1-2019

Table 15 (Continued)

Occupancy Category	People Outdoor Air Rate R_p		Area Outdoor Air Rate R_p		Default Values Occupant Density #/1000 ft ² or #/100 m ²	Air Class	OS (6.2.6.1.4)
	cfm/person	L/s-person	Cfm/ft ²	L/s m ²			
Miscellaneous Space (continued)							
Sorting, packing, light assembly	7.5	3.8	0.12	.06	7	2	
Telephone closets	-	-	0.00	.00	-	1	
Transportation waiting	7.5	3.8	0.06	.03	100	1	
Warehouses	10	5	0.06	.03	-	2	
Office Buildings							
Breakrooms	5	2.5	0.12	0.6	50	1	
Main entry lobbies	5	2.5	0.06	0.3	10	1	
Occupiable storage rooms for dry materials	5	2.5	0.06	0.3	2	1	
Office space	5	2.5	0.06	0.3	5	1	
Reception areas	5	2.5	0.06	0.3	30	1	
Telephone data entry	5	2.5	0.06	0.3	60	1	
Outpatient Health Care Facilities ^{a,b}							
Birth room	10	5	0.18	0.9	15	2	
Class 1 imaging rooms	5	2.5	0.12	0.6	5	1	
Dental operator	10	5	0.18	0.9	20	1	
General examination room	7.5	3.8	1.12	0.6	20	1	
Other dental treatment areas	5	2.5	0.06	0.3	5	1	
Physical therapy exercise area	20	10	0.18	0.9	7	2	
Physical therapy individual room	10	5	0.06	0.3	20	1	
Physical therapeutic pool area	-	-	0.48	2.4	-	1	√
Prosthetics and orthotics room	10	5	0.18	0.9	20	1	√
Psychiatric consultation room	5	2.5	0.06	0.3	20	1	
Psychiatric examination room	5	2.5	0.06	0.3	20	1	
Psychiatric group room	5	2.5	0.06	0.3	50	1	
Psychiatric seclusion room	10	5	0.06	0.3	5	1	
Speech therapy room	5	2.5	0.06	0.3	20	1	
Urgent care examination room	7.5	3.8	0.12	0.6	20	1	
Urgent care observation room	5	2.5	0.06	0.3	20	1	
Urgent care treatment room	7.5	3.8	0.18	0.9	20	1	
Urgent care triage room	10	5	0.18	0.9	20	1	

Source: ASHRAE 62.1-2019

Table 15 (Continued)

Occupancy Category	People Outdoor Air Rate R_p		Area Outdoor Air Rate R_p		Default Values Occupant Density #/1000 ft ² or #/100 m ²	Air Class	OS (6.2.6.1.4)
	cfm/person	L/s-person	Cfm/ft ²	L/s m ²			
Public Assembly Spaces							
Auditorium seating area	5	2.5	0.06	.03	150	1	√
Courtrooms	5	2.5	0.06	.03	70	1	√
Legislative Chambers	5	2.5	0.06	.03	50	1	√
Libraries	5	2.5	0.12	.06	10	1	
Lobbies	5	2.5	0.06	.03	150	1	√
Museums (children's)	7.5	3.8	0.12	.06	40	1	
Museums/galleries	7.5	3.8	0.06	.03	40	1	√
Places of religious worship	5	2.5	0.06	.03	120	1	√
Retail							
Sales (except as below)	7.5	3.8	0.12	0.6	15	2	
Barbershop	7.5	3.8	0.06	0.3	25	2	√
Beauty and nail salons	20	10	0.12	0.6	25	2	
Coin-operated laundries	7.5	3.8	0.12	0.6	20	2	
Mall common areas	7.5	3.8	0.06	0.3	40	1	√
Pet shops (animal areas)	7.5	3.8	0.18	0.9	10	2	
Supermarket	7.5	3.8	0.06	0.3	8	1	√
Sports and Entertainment							
Bowling Alley (seating)	10	5	12	0.6	40	1	
Disco dance floors	20	10	0.06	0.3	100	2	√
Gambling casinos	7.5	3.8	0.18	0.9	120	1	
Game arcades	7.5	3.8	0.18	0.9	20	1	
Gym, sports arena (play area)	20	10	0.18	0.9	20	1	
Health club/aerobics room	20	10	0.06	0.3	40	2	
Health club/weight rooms	20	10	0.06	0.3	10	2	
Spectator areas	7.5	3.8	0.06	0.3	150	1	√
Stages, studios	10	5	0.06	0.3	70	1	√
Swimming (pool and deck)	-	-	0.48	2.4	-	2	
Transient Residential							
Common corridors	-	-	0.06	0.3		1	√
Dwelling unit	5	2.5	0.06	0.3	F	1	√

Source: ASHRAE 62.1-2019

Table 16: Minimum Exhaust Rates

Occupancy Category	Exhaust Rate, cfm/unit	Exhaust Rate, cfm/ft ²	Notes	Exhaust Rate, l/s unit	Exhaust Rate, l/s unit m ²	Air Class
Animal Facilities						
Animal imaging (MRI-CT-PET)	-	0.90	-	-	4.5	3
Animal operating rooms	-	3.00	-	-	15	3
Animal postoperative recovery room	-	1.50	-	-	7.5	3
Animal preparation rooms	-	1.50	-	-	7.5	3
Animal procedure room	-	2.25	-	-	11.3	3
Animal surgery scrub	-	1.50	-	-	7.5	3
Large-animal holding room	-	2.25	-	-	11.3	3
Necropsy	-	2.25	-	-	11.3	3
Small-animal cage room (static cages)	-	2.25	-	-	11.3	3
Small-animal cage room (ventilated cages)	-	1.50	-	-	7.5	3
Arenas	-	0.50	B	-	-	1
Art classrooms	-	0.70	-	-	3.5	2
Auto repair rooms	-	1.50	A	-	7.5	2
Barber shops	-	0.50	-	-	2.5	2
Beauty and nail salons	-	0.60	-	-	3.0	2
Cells with toilet	-	1.00	-	-	5.0	2
Copy, printing rooms	-	0.50	-	-	2.5	2
Darkrooms	-	1.00	-	-	3	2
Educational science laboratories	-	1.00	-	-	5	2
Janitor closets, trash rooms, recycling	-	1.00	-	-	5	3
Kitchenettes	-	0.30	-	-	1.5	2
Kitchens-commercial	-	0.70	-	-	3.5	2
Locker rooms for athletic, industrial, and health care facilities	-	0.50	-	-	2.5	2
All other locker rooms	-	0.25	-	-	1.25	2
Shower rooms	20/50	-	-	10/25	-	2
Paint spray booths	-	-	F	-	-	4
Parking garages	-	0.75	C	-	3.7	2
Pet shops (animal areas)	-	0.90	-	-	4.5	2
Refrigerating machinery rooms	-	-	F	-	-	3
Residential kitchens	50/100	-	G	25/50	-	2
Soiled laundry storage rooms	-	1.00	F	-	5	3
Storage rooms, chemical	-	1.50	F	-	7.5	4
Toilets - private	25/50	-	E,H	12.5/25	-	2
Toilets - public	50/70	-	D,H	25/35	-	2
Woodwork shop classrooms	-	0.50	-	-	2.5	2

Source: ASHRAE 62.1-2019

Table 17: Airstreams or Sources

Description	Air Class
Commercial kitchen grease hoods	4
Commercial kitchen hoods other than grease	3
Diazo printing equipment discharge	4
Hydraulic elevator machine room	2
Laboratory hoods	4
Paint spray booths	4
Refrigerating machinery rooms	3
Residential kitchen hoods in transient occupancy	3

Table 18: Typical Model Code Exhaust Flow Rates for Conventional Type 1 Hood

Wall-mounted canopy	Q = 0.5A
Single-island canopy	Q = 0.75A
Double-island canopy	Q = 0.5Av
Eyebrow	Q = 0.5A
Back shelf/Pass-over	Q = 0.45 x Length of hood

Source: Guidelines on Energy Conserving Design of Buildings, 2007

Notes:

Q = exhaust flow rate, cu. m/sec

A = area of hood exhaust aperture, m²

Table 19: Maximum Water Velocity to Minimize Erosion

Normal Operation (hours per year)	Water Velocity (m/s)
1500	3.1
2000	2.9
3000	2.7
4000	2.4
6000	2.1
8000	1.8

Source: Guidelines on Energy Conserving Design of Buildings, 2007

Note: The noise criteria are not included anymore since noise in piping system is usually caused by entrained air which could be eliminated.

Table 20: Minimum Insulation Thickness for Various Pipes Sizes

Piping System Types	Fluid Temp. Range (°C)	Pipe Sizes (mm)			
		Condensate drains to 50	50 or less	63 to 76	89 and larger
Chilled Water	4.5 to 13.0	25	38	38	50
Refrigerant or Brine	4.5 and below	50	50	63	63

Source: Guidelines on Energy Conserving Design of Buildings, 2007

Note: Insulation thickness (mm) in table above are based on insulation having thermal resistivity in the range of 0.028 to 0.032 m² °C/W-mm on a flat surface at a mean temperature of 24 °C. Minimum insulation thickness shall be increased for materials having K value less than 0.028 m² °C/W-mm or maybe reduced for materials having K value greater than 0.032 m² °C/W-mm.

Table 21: Standard Rated Conditions for Air Conditioning Systems

Stream	Water Cooled Water Chiller (°C)	Air Cooled Water Chiller (°C)	Water Cooled Package A/C Units, (°C)
Chilled Water Supply	7.0	7.0	-
Chilled Water Return	12.0	12.0	-
Cooling Water Supply	29.5	-	29.5
Cooling Water Return	35.0	-	35.0
Condenser Air Inlet	-	35.0	-
Evaporator Return Air			27.0 (*) 19.0 (**)

Source: Guidelines on Energy Conserving Design of Buildings, 2007

Note:

* Dry Bulb Temperature

** Wet Bulb Temperature

Table 22: Minimum Performance Rating of Various Air Conditioning Systems

Air Conditioning Equipment	EER	kWe/TR
Unitary A/C units	10.3	-
Up to 20 kW _r capacity	9.8	-
21 to 60 kW _r capacity	9.7	-
61 to 120 kW _r capacity	9.5	-
Over 120 kW _r capacity		
Scroll chillers (up to 175 kW _r)		
Air cooled	-	1.0
Water cooled	-	0.8
Screw chillers (above 245 kW _r)		
Air cooled	-	0.8
Water cooled	-	0.65
Centrifugal chillers (up to 14 kW _r)		
Water cooled	-	0.58

Notes:

EER = kJ/kWh

See Equation 6.10.4

kWe/TR = kilowatt electricity per ton of refrigeration 1TR = 3.51685kW_r

Table 23: Size of Opening for Natural Lighting & Ventilation

Type of Occupancy or Usage of Room	x% of Floor Area of Room	y% of x open a
Residential	15%	50%
Store, Utility, Garage (In residential premises)	10%	50%
Water-closet, Toilet, Bathroom Laundry	10% or 0.2 m ² (whichever is greater)	100%
Business	15%	50%
School classroom	20%	50%
Hospital, Nursing home	15%	100%
Lobby, Corridor, Staircase	10%	50%
Warehouse	10%	50%

Source: Guidelines on Energy Conserving Design of Buildings, 2007

Table 24: Fresh Air Supply for Mechanical Ventilation

Type of Building/Occupancy	Minimum Fresh Air Supply	
	Air change per hour	M /h per person
Office	6	18
Restaurant, Canteen	6	18
Shop, Supermarket, Department Store	6	18
Workshop, Factory	6	18
Classroom, Theater, Cinema	8	–
Lobby, Concourse, Corridor, Staircase	4	–
Toilet, Bathroom	10	–
Kitchen (commercial, institutional & industrial)	20	–
Car Park	6	–

Source: Guidelines on Energy Conserving Design of Buildings, 2007

Note: Unless justified by exceptional circumstances, the ventilation rate shall not be exceeded by more than 30% of the above values.

Table 25: Maximum Net Exhaust Flow Rate, cfm per Linear Foot of Hood Length

Type of Hood	Light-Duty Equipment	Medium-Duty Equipment	Heavy-Duty Equipment	Extra-Heavy-Duty Equipment
Wall-mounted canopy	140	210	280	385
Single island	280	350	420	490
Double island (per side)	175	210	280	385
Eyebrow	175	175	NA	NA
Backshelf/pass-over	210	210	280	NA

NA: Not allowed

Table 26: Minimum Duct Insulation R-Value

Climate Zone	Duct Location		
	Unconditioned Space and Buried		
	Exterior ^h	Ducts	Indirectly Conditioned Space ^{c,d}
Supply and Return Ducts for Heating and Cooling			
0 to 4	R-8	R-6	R-1.9
5 to 8	R-12	R-6	R-1.9
Supply and Return Ducts for Heating Only			
0 to 1	None	None	None
2 to 4	R-6	R-6	R-1.9
5 to 8	R-12	R-6	R-1.9
Supply and Return Ducts for Cooling Only			
0 to 6	R-8	R-6	R-1.9
7 to 8	R-1.9	R-1.9	R-1.9

Table 27: Minimum Piping Insulation Thickness Cooling Systems

Fluid Operating Temperature Range (°F) and Usage	Insulation Conductivity		Nominal Pipe or Tube Size, In.				
	Conductivity, Btu·in/h·ft ² ·°F	Mean Rating Temperature, °F	<1	<1 to <1-1/2	1-1/2 to <4	4 to <8	≥8
			Insulation Thickness, In.				
40 to 60	0.21 to 0.27	75	0.5	0.5	1.0	1.0	1.0
<40	0.20 to 0.26	50	0.5	1.0	1.0	1.0	1.5

Source: ASHRAE 90.1-2019

Table 28: Air Conditioning Checklist

Location:		City:	Province:	
		Standard	Actual	Remarks
1. Building Site Assessment				
1.1	Location and building foot print _____sq.m.			
1.2	Building Orientation (North, South or East West) _____			
2. Air Conditioning System COP, EER or CSPF Rating				
2.1	Window Room Air Conditioning Unit			
2.2	Split Type Air Conditioning			
2.3	VRF/VRV Air Conditioning System			
2.4	Centralized Water Cooled			
2.5	Centralized Air Cooled			
3. Ventilation in kW per CFM (kW per CMH)				
3.1	Basement Carpark Ventilation			
3.2	Attic/Interstitial Space Ventilation			

Source: Philippine Green Building Code

Section VI. Steam and Hot Water System

6.1 Scope

This section applies to the energy conserving design of steam and hot water services in buildings that include but are not limited to hotels, restaurants, hospitals, and laundry shops. The purpose of this section is to provide the criteria and minimum standards for energy efficiency in the design and equipment selection that will provide energy savings when applied to steam and hot water systems.

6.2 System Design and Sizing

- A. The system with the lowest overall energy usage (considering the heat losses in the calorifier and the circulating loop of a centralized system and the total heat losses from a system of individual storage heater) shall be chosen.
- B. Steam is more economical compared with electricity. Where steam is available, use steam to generate hot water instead of electricity.
 - 1. Use a heat exchanger to heat the water from steam.
 - 2. Heat pump may also be used to produce hot water. A heat pump is a refrigeration system with the condenser as a source of heat.
- C. When steam is used, a centralized hot water generator shall be placed as near as possible to the steam source in order to reduce piping heat losses.
- D. For generation of steam, use boiler with an efficiency rating of 85% and above.

- E. In the absence of steam, use a direct-fired hot water generator with an efficiency rating of 85% and above.
- F. Use a solar water heater on the roof top with 3 kW electric heater back up to be used during prolonged rains.
 - 1. Types of solar water heat absorbers are as follows:
 - a. Copper serpentine type solar hot water heat absorber with a capacity of 300 liters and 150 liters storage capacity
 - b. Vacuum tube absorber type solar hot water with a capacity of 300 liters and 150 liters storage capacity.
 - 2. This can be installed with a pipe header and a solar water heat absorber in multiples of either 300 liters or 150 liters daily heating capacity with a centralized insulated hot water tank and an equivalent electric heater backup in case of prolonged rains for residential condominiums, hotels, and hospitals.
 - 3. Solar energy use in water heating is for commercial, hotels, hospitals, and medium to high-rise residential building applications. See *Table 34, Renewable Energy Ready Home Solar Water Heating Checklist* as a guide to its efficiency design.
 - 4. Solar water heaters can also be used as pre-heated feed water to steam boilers or calorifier for efficiently producing hot water.
- G. All forms of losses shall be minimized, if not eliminated, such as the following:
 - 1. Insufficient insulation
 - 2. Pipe leakage.

6.3 Minimum Equipment Efficiency

All boilers and hot water storage tanks shall meet the criteria in *Tables 29, 30, 31*.

Exception: Hot water storage tanks having more than 2 m³ of storage capacity need to meet the standby loss or heat loss requirements of Table 29 if the tank surface is thermally insulated with suitable insulating material with $R = 0.045 \text{ m}^2 \cdot \text{°C}/\text{W-mm}$.

6.4 Hot Water Temperature

The maximum hot water supply temperatures shall be as follows:

For washing, etc.	45°C
For hot bath	45°C
For kitchen use	60°C

It is recommended that two separate systems be installed when two different temperatures (hot and cold) are required, to minimize piping heat losses. This shall always be done where the demand at the lower temperature is greater than 25% of the demand at higher temperature.

6.5 Controls

- A. Hot water systems shall be equipped with effective automatic temperature controls, which are capable of holding the water temperature to $\pm 3^\circ\text{C}$ of the temperatures set in the subsection on hot water temperature above.
- B. Systems designed to maintain usage temperatures in the circulating loop shall be equipped with automatic time switches or other controls that can be set to turn off the system when use of hot water is not required.
- C. Manual controls shall also be provided to override the automatic controls when necessary. Controls shall be accessible to operating personnel.
- D. Controls for Hot Water Conservation
 - 1. Showers in bathrooms shall have outlets, which restrict the flow to no more than 0.2 L/s. Lavatories in public areas of the buildings shall have taps with controlled flow at a rate not exceeding 0.05 L/s. This applies to both cold and hot water taps when separate taps are used.
 - 2. Single outlet mixing taps with a flow of 0.5 L/s shall be used to separate cold and hot water taps.

3. Point of use water heaters, which are installed where hot water is needed, shall only be considered if their use is guaranteed to reduce energy cost.

6.6 Piping Insulation

A. Circulating Systems

The insulation of steam, condensate, and hot water lines shall conform to the requirements in *Table 30* or an equivalent level as calculated in accordance with the following equation:

$$t_2 = 50.8 d_o [(1 + 2 t_1/d_o) \exp^{(r_2/r_1)} - 1]$$

Where:

- t_2, t_1 = minimum insulation thickness of materials with
- r_1 and r_2 thermal resistivity, respectively, mm
- r_2, r_1 = thermal resistivities, $m^2-^{\circ}C/W-mm$
- d_o = outside pipe diameter, m

Subscript 1 refers to values quoted in *Table 30*; subscript 2 refers to values corresponding to alternate insulating material.

Notes: The use of asbestos in any portion of the piping system is not allowed.

B. Non-circulating System

The first 2.5 m of outlet piping from a storage system that is maintained at a constant temperature and inlet pipe between the storage tank and the heat trap shall be insulated as provided in *Table 30*, or to an equivalent level as calculated in accordance with Equation 7.1.

6.7 Waste Heat Recovery and Utilization

- A. Consider the use of condenser heat, waste heat, or solar energy to supplement hot water requirements.

Recover waste heat from the chilled water system for water heating where the base requirement is 85°F (29.4°C). To maximize the captured heat without decreasing the chiller plant efficiency, the system shall accomplish the following:

1. Capture sufficient heat for useful purposes
2. Minimize chiller lift and maximize chiller efficiency
3. Control the hot water temperature without sacrificing the stable plant operation.

- B. Storage shall be used to optimize heat recovery when the flow of heat to be recovered is out of phase with the demand for hot water.

Table 29: Minimum Performance Ratings of Steam and Hot Water Systems Equipment

Equipment	Minimum Criteria
Shell Boiler (light oil fired) @ Rated capacity @ Part load capacity	85% thermal efficiency 80% thermal efficiency
Shell Boiler (heavy oil fired) @ Rated capacity @ Part load capacity	85% boiler efficiency 80% boiler efficiency
Unfired Storage Tanks (all volumes) Surface heat loss (maximum)	43 W/m ²

Source: Guidelines on Energy Conserving Design of Buildings, 2007

Table 30: Baseline Thermal Efficiency Levels for Commercial Water Heater Equipment

Equipment Class		Thermal Efficiency
Electric storage water heaters		–
Commercial gas-fired storage water heaters and gas-fired storage-type instantaneous water heaters		80%
Residential-duty gas-fired storage water heaters		80%
Gas-fired instantaneous water heaters and hot water supply boilers	Tankless water heaters	80%
	Hot water supply boilers	80%

Source: Guidelines on Energy Conserving Design of Buildings, 2007, with revisions from ENPAP 4.0

Table 31: Baseline Standby Loss Levels for Representative Commercial Water Heater Equipment

Equipment Class		Representative Storage Volume gal*	Representative Input Capacity kBTU/h or kW	Baseline Standby Loss Level BTU/h
Electric storage water heaters		119 (rated, 114 (measured))	18kW	353
Commercial gas-fired storage water heaters and gas-fired storage-type instantaneous water heaters		100	199 kBTU/h	1349
Residential-duty gas-fired storage water heaters		75	76 kBTU/h	1048
Gas-fired instantaneous water heaters and hot water supply boilers	Tankless water heaters	<10	250 kBTU/h	250
	Hot water supply boilers	A11	399 kBTU/h	399

Source: Guidelines on Energy Conserving Design of Buildings, 2007, with revisions from ENPAP .4.0

* For all equipment classes not specified, the representative volume is a rated storage volume, not a measured storage volume.

Table 32: Minimum Pipe Insulation (Heating System)

System Types	Fluid Temp. Range (°C)	Pipe Sizes (mm)				
		Runouts to 50	25 or less	31 to 50	63 to 76	89 and larger
Steam and Condensates	>180 (a)	38	63	63	76	89
	120-180 (b)	38	50	63	63	89
	95-120 (c)	25	38	50	50	50
	60-95 (d)	12	38	38	38	38
	40-60 (e)	12	25	25	25	38
Hot Water	40 & above (e)	12	25	25	38	38

Source: Guidelines on Energy Conserving Design of Buildings, 2007

Note: Thermal resistivity ($m^2 \cdot ^\circ C / W \cdot mm$) ranges areas follows: (a) $R = 0.020-0.022$
 (b) $R = 0.022-0.024$
 (c) $R = 0.023-0.026$
 (d) $R = 0.02i -0.028$
 (e) $R = 0.025-0.029$

Table 33: Minimum Piping Insulation Thickness and Hot Water Systems

Fluid Operating Temperature Range (°F) and Usage	Insulation Conductivity		≥Nominal Pipe or Tube Size, In.				
	Conductivity, Btu-in/h-ft ² -°F	Mean Rating Temperature, °F	<1	<1 to <1-1/2	1-1/2 to <4	4 to <8	≥8
			Insulation Thickness, In.				
>350	0.32 to 0.34	250	4.5	5.0	5.0	5.0	5.0
251 to 350	0.29 to 0.32	200	3.0	4.0	4.5	4.5	4.5
201 to 250	0.27 to 0.30	150	2.5	2.5	2.5	3.0	3.0
141 to 200	0.25 to 0.29	125	1.5	1.5	2.0	2.0	2.0
105 to 140	0.22 to 0.28	100	1.0	1.0	1.5	1.5	1.5

Source: ASHRAE 90.1-2019

Table 34. Renewable Energy Ready Solar Water Heating Checklist

Location: _____ City: _____ Province: _____

1 Building/Array Site Assessment			
1.1	Designate a proposed array location and square footage on architectural diagram _____sq.ft.		
1.2	Identify orientation (azimuth) of proposed array location: _____ degrees.		
1.3	Identify inclination of proposed array location: _____ degrees.		
1.4	Conduct a shading study documenting impacts on proposed array location _____% adjusted annual shading impact. If using monthly values as verified through the solar path assessments, check here: _____.		
1.5	Assess if proposed array location supports a solar resource potential of more than 75% of the optimal solar resource potential for the same location using the online RERH Solar Site Assessment Tool (SSAT) Yes. This home meets the minimum recommended solar resource potential per the RERH SSAT results; continue with Section 2 below. No. This array location does not meet the recommended solar resource potential per the RERH SSAT results; this location is not a good host for a future solar energy system and should not be made renewable energy ready.		
2 Structural and Safety Considerations: Solar Water Heating			
2.1	Provide code-compliant documentation of the maximum allowable dead load and live load ratings of the existing roof; dead load rating should support an additional 6 lbs/sq ft for future solar system.		
2.2	Provide code-compliant documentation of the maximum allowable floor load rating for storage tanks installed on non-concrete floors.		
2.3	Install permanent roof anchor fall safety system (NA for roof pitch ≤ 3:12)		
3 Renewable Energy Ready Home Infrastructure: Solar Water Heating			
3.1	Dedicate and label a 3' x 3' x 7' area in the utility room adjacent to the existing water heater for a solar hot water tank.		
3.2	Dedicate and label a 3' x 2' plywood panel area adjacent to the solar hot water tank for the balance of system components/pumping package.		
3.3	Install an electrical outlet with 6' of the designated wall area (3.2)		
3.4	Install a solar bypass valve on the cold water feed of the water heater (cap and label both ends).		
3.5	Install a single 4" chase or 2-2' chases from utility room to the attic space below designated array location (cap and label both ends).		
3.6	Provide architectural drawing and plumbing riser diagram of RERH SWH system components.		

Table 34 (Continued)

4 Homeowner Education			
4.1	Provide to the homeowner a copy of this checklist and all the support documents listed below (to be provided to the future solar designer).		
	- Copy of the Renewable Energy Ready Home Specification guide		
	- Fully completed RERH checklist (all sections)		
	- Architectural drawings detailing proposed array location and square footage		
	- Plumbing riser diagram of RERH solar water heating system components and their locations		
	- Shading study with percent monthly or adjusted annual shading impact(s)		
	- Site assessment record generated by the online RERH SSAT indicating that the proposed site meets a minimum solar resource potential of 75 percent of optimal		
	- Code-compliant documentation of the maximum allowable dead load and live load ratings of the roof		
	- Code-compliant documentation of the maximum allowable floor load rating for storage tanks installed on non-concrete floors		
5 Builder Best Practices (Optional Elements)			
5.1	Develop a detailed landscape plan with a clear emphasis on low-growth vegetation		
5.2	Place roof penetrations above or north of the proposed array to prevent casting shadows on the array		
	Builder Completion Date: _____	Builder Company Name: _____	
	Builder Employee Name: _____	Builder Employee Signature: _____	

Source: Philippine Green Building Code

Table 35: Steam and Hot Water System Checklist

Location: Province:		City:			
		Standard	Actual	Remarks	
1. Steam Generation System, Liter Fuel per kilo or kilo of fuel per kilo of Steam Produced					
1.1	Fire Tube Boiler				
1.2	Biomass Boiler				
1.3	Water Tube Boiler				
2. Hot Water Generation System, Liter Fuel per Liter or kW of Electricity per liter of Hot Water Produced					
2.1	Electric Water Heater				
2.2	Caldera Type Hot Water Generator				

Source: Guidelines on Energy Conserving Design of Buildings, 2007

PART III
ELECTRICAL SYSTEMS

Section VII. Lighting

7.1 Scope

This section shall apply to the lighting of spaces and areas of buildings, such as:

- A. Interior spaces of buildings;
- B. Exterior areas of buildings such as entrances, exits, loading docks, parking areas, etc.;
- C. Roads, grounds and other exterior areas including open-air covered areas where lighting is required and is energized through the building's electrical service.

7.2 Exemptions

Only research laboratories with special lighting are exempted but are encouraged to use energy-efficient lighting system, whenever applicable.

7.3 General Requirements of Energy-Efficient Lighting Design

These set out the minimum requirements for achieving energy-efficient lighting installations. These are generally expressed in terms of illumination level, luminous efficacy, and lighting power density. In the course of selecting an appropriate indoor illumination level for a space, energy efficiency shall be taken into consideration, in addition to other lighting requirements.

On the other hand, specific efficiency requirements for each type of lamp, control gear/ballast, and luminaire shall conform to the Minimum Energy Performance (MEP) for Products established by DOE.

- A. Buildings shall be planned and designed to maximize the use of natural light so as to reduce the use of artificial illumination. The lighting system shall be so designed that day lighting can be coordinated with artificial lighting, taking into consideration the problems of glare, brightness imbalance, and heat buildup in the building interiors. All regularly occupied spaces inside the building shall have a view of any combination of the following features that can allow daylight into the room space:
1. Window
 2. Light shelf
 3. Clerestory
 4. Skylight
 5. Light monitor/light scoop
 6. Other devices that can allow daylight inside

However, the design shall ensure that whatever is saved from the lesser use of artificial lighting shall not be lost due to the increase in air conditioning load. Hence, the Window-to-Wall Ratio (WWR) shall be balanced with the Solar Heat Gain Coefficient (SHGC) of the glass to maintain flexibility in design.

- B. The lighting design shall utilize energy-efficient lighting equipment. The lighting system shall be so chosen so as to provide a flexible, effective and pleasing visual environment in accordance with the intended use, but with the least possible energy requirements.
- C. The use of task-oriented lighting shall be used whenever practicable.

- D. In the design of general lighting in buildings with centralized air conditioning equipment, consideration shall be given to integrated lighting and air conditioning systems which use luminaires with heat removal capabilities. (See related requirements in Section V. Air Conditioning and Ventilating System.)
- E. The lighting system shall be designed for expected activity. The task shall be analyzed in terms of difficulty, duration, criticalness, and location in order to determine the lighting needs throughout the space, always keeping in mind that higher illumination levels than necessary are likely to waste energy, while on the other hand, levels lower than needed could impair visual effectiveness. *Table 36* lists the recommended illuminance levels.
- F. Buildings with at least ten (10) storeys shall have at least one light in each corridor, emergency exit, and stairwell per storey. Each elevator shall also have at least one light, which shall always be lit and designed to have a separate circuit from the usual lighting circuit, which is not controllable by a switch, and is supplied by the UPS System of the building.
- G. The designer shall select the most efficient lamps, the proper color rendition and the desired color appearance appropriate for the type of lighting needed for the space to be lit. Using these lamps reduce power requirements. Refer to *Table 37*, Efficacy Ranges and Color Rendering Indices of Various Lamps.
- H. In general, the normal artificial light source shall be the compact fluorescent lamp (CFL) or LED lamp. In down light installation, CFL or LED lamps can be used. In large high bay areas, high-pressure discharge lamps, induction lamps, or LED lamps are more appropriate. If color rendering is comparatively of minor importance, lamp types with Color Rendering Index (CRI) of less than 50 can be used. However, when good color rendering is required, lamp types with CRIs of 50 and above shall be used. Please refer to *Table 37* for the CRIs of the different lamp types.

- I. The most efficient combination of luminaires, lamps, and ballasts appropriate for the lighting task and for the environment shall be selected so that lamp light output is used effectively. The selected luminaire shall meet the requirements with respect to light distribution, uniformity, and glare control. The use of highly polished or mirror reflectors are recommended to reduce the number of lamps installed without reducing the illumination level. Where ballasts are used, these shall be of the electronic type or low loss type with a power factor of at least 85%.
- J. The highest practical room surface reflectance shall be considered in the lighting design. The use of light finishes shall attain the best overall efficiency of the entire lighting system. Dark surfaces shall be avoided because these absorb light. *Table 38* lists the recommended room surface reflectance.
- K. Selective switching possibilities shall be provided so that individual, or a specific group of fixtures, can be turned off when not needed, and lighting levels can be adapted to changing needs.
- L. In selecting lighting systems, the costs of operation and energy usage (i.e., the Life Cycle Cost or Cost of Ownership), and not simply the initial cost, shall be considered.

7.4 Lighting Power Density (LPD)

Limiting LPD will encourage the use of efficient lighting systems and reduce the lighting load in the buildings and surrounding facilities. Hence, all applicable building types shall comply with the LPD limits described in the following provisions:

- A. The total lighting power density for the interior spaces of buildings shall not exceed the maximum values for building areas/activities as specified in *Table 39*.
- B. Lighting power requirements for building exteriors, including walk/drive ways and grounds, shall not exceed the values given in *Table 40*.

7.5 Lighting Controls

All lighting systems, except those required for emergency or exit lighting for security and/or safety purposes, shall be provided with manual, automatic, or programmable controls.

- A. Building interior perimeter zones exposed to daylight generally do not require artificial lighting during the day. Where adequate day lighting is available, local manual or automatic controls such as photoelectric switches or automatic dimmers shall be provided in day-lit spaces. Controls shall be provided so as to operate rows of lights parallel to the facade/ exterior wall. Lighting fixtures within the daylight zone shall be controlled with photoelectric sensors with an auto on-off basis or continual dimming. The photoelectric sensor shall be located approximately at half ($\frac{1}{2}$) the depth of the daylight zone.

- B. If occupancy sensors are installed in the daylight zone, the occupancy sensor shall override the photoelectric sensor during non-occupancy periods. For residential condominiums, this applies only to common indoor areas with access to daylight. Installed lighting fixtures within the day-lit zones are exempt from using photoelectric sensor if this hinders its intended functions, with justification for exemption to be submitted along with the building permit application.
- C. Occupancy sensors linked to lighting shall be installed in areas with variable occupancy, except for hospitals and malls and for emergency and security lighting, such as the following areas:
1. Corridors
 2. Private offices
 3. Storage rooms
 4. Common toilets
 5. Meeting rooms
 6. Stairways
 7. Other similar areas

For covered car parks, minimum of sixty per cent (60%) of the lighting shall be controlled by the occupancy sensors.

- D. Each space enclosed by walls or ceiling-height partitions shall be provided with at least one lighting control, capable of turning off all the lights within the space.
- Exception: Continuous lighting required for emergency/security purposes*
- E. One lighting control point shall be provided for each task lighting.
- F. The general lighting of any enclosed area 10 m² or larger in which the connected load exceeds 10 W/m² for the whole area shall be

controlled so that the load for the lights may be reduced by at least 50%, while maintaining a reasonably uniform level of illuminance throughout the area. This may be done with the use of dimmers, by dual switching of alternate lamps, or by switching each luminaire or each lamp.

- G. When dimming control of lighting will be needed, rheostat-based dimmers shall not be used; only electronic dimmers are allowed.
- H. The number of fixtures or lamps shall be limited per lighting circuit to provide greater flexibility, provided, it shall also comply with section E. For the purpose of determining the total number of control points, *Table 41* shall be used.
- I. Exterior lighting not intended for 24 hours' continuous use shall be automatically switched by a timer, photocell, or a timer-photocell combination but provided with manual override.
- J. Hotel and motel guest rooms shall have one master switch at the main entry door that turns off all permanently wired lighting fixtures and switched receptacles, except for security lighting, if required. This switch may be activated by the insertion and removal of the room key.
- K. Feature display lighting in retail and wholesale stores shall be separately switched on circuits not more than 20 amperes capacity. If there are more than four of these display circuits, the display lighting shall be automatically controlled by a programmable timer with provisions for temporary override by store personnel.
- L. Valance lighting in retail and wholesale stores shall be switched independent of general and display lighting.

7.6 Control Location

- A. All lighting controls shall be installed near the point of entry and shall be readily accessible to space occupants.
- B. Switches for task lighting areas may be mounted as part of the task lighting fixtures. Switches controlling the same load from more than one location shall not be credited as increasing the number of controls to meet the requirements of this subsection.

Exceptions:

- 1. Lighting control requirements for spaces, which shall be used as a whole, shall be controlled in accordance with the work activities and controls may be centralized in remote locations. These areas include public lobbies of office buildings, hotels and hospitals; retail and department stores and warehouses; storerooms and service corridors under centralized supervision.
- 2. Manual and automatic control devices may reduce the number of controls required by using an equivalent number of controls from *Table 41*.
- 3. Automatic controls
- 4. Programmable controls
- 5. Controls requiring trained operators
- 6. Controls for safety hazards and security

7.7 Required Design Documentation

The following documents shall be required for the building permit application:

- A. Architectural and electrical lighting layout plan showing the location of lighting receptacles and manual/automatic switches/controls, together with the lighting and lighting control technical specifications

- B. Technical data sheets/brochures of lamps, ballast (if applicable), and luminaires.
- C. Lighting power density computation and projected illumination per area/application.
- D. Relevant drawings and plans

**Table 36: Recommended Design Illuminance Levels
(Based from IESNA Lighting Handbook)**

Task	Min. & Max. (Lux)	Applications
Lighting for infrequently used areas	50 – 100	Stairways, corridors, and Parking-Interior
	50 – 200	Storage Room-General
	100 – 300	Loading Docks, Locker Rooms, Lounge/Break Rooms and Restrooms/Toilets
	200 – 300	Bedroom-Dormitory, Cafeteria-Eating, Gymnasium-Exercise/Workout, and Lobby-Office/General
	200 – 500	Library-Stacks, Mechanical/Electrical Rooms and Retail Sales
Lighting for working and activity interiors	300 – 500	Classrooms-General, Conference Rooms, Exhibit Space, Gymnasium-Sports/Games, Library-Reading/Studying, Office-Open, and Office-Private/Closed
	300 – 750	Kitchens-Food Preparation and Workshops
Localized lighting for exacting tasks	500 – 750	Laboratory-Classrooms
	750 – 1200v	Laboratory-Professional

Table 37: Minimum Energy Performance, Efficacy Ranges and Color Rendering Indices of Various Lamps

Lamp Type	Rated Power Ranges (watts)	Efficacy Ranges (lumens per watt)	Minimum Color Rendering Index (CRI)
Incandescent Lamp	10–100	10–25	100
Compact Fluorescent Lamp (CFL)			
Bare Lamp	3– 60	41–65	80
Encapsulated	3– 60	35–55	80
Linear/Double Capped Fluorescent Lamp			
Halophosphor	10–65	55–70	70
Triphosphor	14–65	60–83	80
Triphosphor T5	14–35	80–95	80
Single Capped (Circular) Fluorescent Lamps			
Halophosphor	14–45	40–55	70
Triphosphor	14– 45	50– 65	80
LED Lamp Self-ballasted (E27)			
Linear/Double Capped	1–120	80–124	80
G5	14–20	90–126	80
G13	6–10	90–126	80
External Induction (Electrode-less) Lamps	100–200	65–87	80–90
Mercury Vapor Lamp	50–2000	40–63	20
Metal Halide Lamp	up to 1000	75–95	65
Low Pressure Sodium Lamp	20–200	100–180	0
High Pressure Sodium Lamp	50–250	80–130	21

Note: Most of the data in the above table provided by DOE-LATL

Table 38: Recommended Room Surface Reflectances

Surface	% Reflectance
Ceilings	80-92
Walls	40-60
Furniture	26-44
Floors	21-39

Source: Guidelines on Energy Conserving Design of Buildings, 2007

Table 39: Maximum Lighting Power Density for Building Interiors

Building Area Type	Lighting Power Density (W/m ²)
Automotive Facility	8.1
Convention Center	6.9
Courthouse	8.5
Dining: Bar lounge/leisure	8.6
Dining: Cafeteria/Fast Food	8.2
Dining: Family	7.6
Dormitory	5.7
Exercise Center	7.7
Fire Station	6.0
Gymnasium	8.2
Health-Care Clinic	8.7
Hospital	10.3
Hotel/Motel	6.0
Library	8.9

Table 39: Maximum Lighting Power Density for Building Interiors (Continued)

Building Area Type	Lighting Power Density (W/m ²)
Manufacturing Facility	8.8
Motion Picture Theater	4.7
Multifamily	4.8
Museum	5.9
Office	6.9
Parking Garage	1.9
Penitentiary	7.4
Performing Arts Theater	9.0
Police Station	7.1
Post Office	7.0
Religious Facility	7.2
Retail	9.0
School/University	7.7
Sports Arena	8.2
Town Hall	7.4
Transportation	5.4
Warehouse	4.8
Workshop	9.8

Source: ANSI/ASHRAE/IES Standard 90.1-2019

Table 40: Maximum Values for Lighting Power Densities for Building Exteriors

Building Area/Space	Lighting Power
Base Allowance	200 W
Façade Lighting and Special Feature Areas, Walkways and Plazas	1.1 W/m ²
Landscape	0.4 W/m ²
Entry Doors	46 W/Lm
Stairs and Ramps	7.5 W/m ²
Parking Lots and Drives	0.5 W/m ²
All Other Areas not Listed Above	2.2 W/m ²

Source: ANSI/ASHRAE/IES Standard 90.1-2019

Note: W/Lm = watts per linear meter

To calculate the exterior lighting values, multiply the space or area square meter by the lighting power and, then, add the product to the base allowance.

Table 41: Control Types and Equivalent Number of Control Points

Type of Control	Continuous (Automatic) dimming
Manually operated on-off switch	1
Occupancy Sensor	2
Timer – programmable from the space being Controlled	2
3 Level step-control (including off) or pre-set Dimming	2
4 Level step-control (including off) or pre-set Dimming	3
Continuous (Automatic) dimming	3

Source: Guidelines on Energy Conserving Design of Buildings, 2007

Section VIII. Electric Motors

8.1 AC Motors

This section shall apply to the energy efficiency requirements of electric motors in buildings.

- A. For general-purpose, T-frame, single speed, foot-mounted, polyphase induction motor of design A and B configuration that is rated for continuous operation and operating at 230 to 480 volts, 60 Hz, as defined in the North American (NEMA) Standard MG 1 and rated from 1 to 200 hp, drip-proof, and totally enclosed fan-cooled enclosures, shall be covered by the efficiency requirements under these guidelines.
- B. A motor's performance shall equal or exceed the nominal full load efficiency levels given in *Table 42*. Motors operating more than 750 hours a year shall be of the energy-efficient types as shown in *Table 43* and shall at a minimum be type IE2 (international efficiency, high). Energy-efficient motors are higher in quality with increased reliability, providing savings from reduced downtime, replacement, operation and maintenance costs.
- C. The nameplates of these motors shall include not only all the information required by the latest edition of the Philippine Electrical Code Part 1, but also the rated full load efficiency and full load power factor as determined by the latest version of Philippine National Standard PNS/IEC 61972 - Methods for Determining Losses and Efficiency of Three Phase Caged Induction Motors.

D. Motor Selection

1. The type and the size of the squirrel-cage induction motor shall be selected only after an accurate determination of the starting and running requirements of the load has been made, taking into account the following factors:
 - a. Maximum overload expected
 - b. Ambient conditions
 - c. Power supply conditions
 - d. Future expansion
 - e. Deterioration of the driven load
 - f. Duty cycle
 - g. Speed
2. The first five factors above shall be considered carefully as these suggest the selection of larger capacity motors, compared with the use of low power factor and low efficiency motors.
3. In cases where higher kW rating is necessary due to special requirements of the application, the motor rating may be increased but shall not exceed 125% of the calculated maximum load to be served. If this rating is not available, the next higher rating may be selected.

Table 42: Minimum Acceptable Full Load Efficiency

Motor Size	Open Drip-Proof Motors			Totally Enclosed Fan-Cooled Motors		
	revolutions per minute			revolutions per minute		
	1200	1800	3600	1200	1800	3600
0.8 kW (1 hp)	72.0	77.0	80.0	–	72.0	75.5
1.2 kW (1.5 hp)	82.5	82.5	82.5	82.5	81.5	78.5
1.6 kW (2 hp)	84.0	82.5	82.5	82.5	82.5	82.5
2.4 kW (3 hp)	85.5	86.5	82.5	84.0	84.0	82.5
4.0 kW (5 hp)	86.5	86.5	85.5	85.5	85.5	85.5
6.0 kW (7.5 hp)	88.5	88.5	85.5	87.5	87.5	85.5
8.0 kW (10 hp)	90.2	88.5	87.5	87.5	87.5	87.5
12.0 kW (15 hp)	89.5	90.2	89.5	89.5	88.5	87.5
16.0 kW (20 hp)	90.2	91.0	90.2	89.5	90.2	88.5
20.0 kW (25 hp)	91.0	91.7	91.0	90.2	91.0	89.5
24.0 kW (30 hp)	91.7	91.7	91.0	91.0	91.0	89.5
32.0 kW (40 hp)	91.7	92.4	91.7	91.7	91.7	90.2
40.0 kW (50 hp)	91.7	92.4	91.7	91.7	92.4	90.2
48 kW (60 hp)	92.4	93.0	93.0	91.7	93.0	91.7
60 kW (75 hp)	93.0	93.6	93.0	93.0	93.0	92.4
80 kW (100 hp)	93.0	93.6	93.0	93.0	93.6	93.0
100 kW (125 hp)	93.6	93.6	93.0	93.0	93.6	93.0
120 kW (150 hp)	93.6	94.1	93.6	94.1	94.1	93.6
160 kW (200 hp)	94.1	94.1	93.6	94.1	94.5	94.1

Source: Guidelines on Energy Conserving Design of Buildings, 2007

Table 43: IEC-NEMA MEP Rating Values for AC Motors

60 Hz										
HP	kW	IE1 - Standard Efficiency			IE2 - High Efficiency			IE3 - Premium Efficiency		
		2-pole	4-pole	6-pole	2-pole	4-pole	6-pole	2-pole	4-pole	6-pole
1	0.75	77	78	73	75.5	82.5	80	77	85.5	82.5
1.5	1.1	78.5	79	75	82.5	84	85.5	84	86.5	87.5
2	1.5	81	81.5	77	84	84	86.5	85.5	86.5	88.5
3	2.2	81.5	83	78.5	85.5	87.5	87.5	86.5	89.5	89.5
5	3.7	84.5	85	83.5	87.5	87.5	87.5	88.5	89.5	89.5
7.5	5.5	86	87	85	88.5	89.5	89.5	89.5	91.7	91
10	7.5	87.5	87.5	86	89.5	89.5	89.5	90.2	91.7	91
15	11	87.5	88.5	89	90.2	91	90.2	91	92.4	91.7
20	15	88.5	89.5	89.5	90.2	91	90.2	91	93	91.7
25	18.5	89.5	90.5	90.2	91	92.4	91.7	91.7	93.6	93
30	22	89.5	91	91	91	92.4	91.7	91.7	94.6	93
40	30	90.2	91.7	91.7	91.7	93	93	92.4	94.1	94.1
50	37	91.5	92.4	91.7	92.4	93	93	93	94.5	94.1
60	45	91.7	93	91.7	93	93.6	93.6	93.6	95	94.5
75	55	92.4	93	92.1	93	94.1	93.6	93.6	95.4	94.5
100	75	93	93.2	93	93.6	94.5	94.1	94.1	95.4	95
125	90	93	93.2	93	94.5	94.5	94.1	95	95.4	95
150	110	93	93.5	94.1	94.5	95	95	95	95.8	95.8
200	150	94.1	94.5	94.1	95	95	95	95.4	96.2	95.8
250	185	94.1	94.5	94.1	95.4	95.4	95	95.8	96.2	95.8
300	220	94.1	94.5	94.1	95.4	95.4	95	95.8	96.2	95.8
350	250	94.1	94.5	94.1	95.4	95.4	95	95.8	96.2	95.8
400	300	94.1	94.5	94.1	95.4	95.4	95	95.8	96.2	95.8
450	330	94.1	94.5	94.1	95.4	95.4	95	95.8	96.2	95.8
500	375	94.1	94.5	94.1	95.4	95.4	95	95.8	96.2	95

Source: IEC/NEMA

- E. Where an application requires varying output operation of motor-driven equipment for any application, a variable speed drive shall be utilized instead of electro-mechanical devices.
- F. Switched Reluctance Motors
 1. Switched reluctance motors (SRM) present several advantages such as high efficiency, maximum operating speed, good performance in terms of torque/inertia ratio, making them an attractive solution to variable speed applications. Their performance strongly depends on the applied control.
 2. Switched reluctance motors are usually designed to operate at various speeds with the highest efficiency. They are used mainly in domestic appliances like vacuum cleaners, washing machines, and general-purpose industrial drives. However, SRMs are now being utilized as power drives for electric vehicles.
- G. Other applicable requirements specified in the latest edition of the Philippine Electrical Code Part 1 shall be complied with.

8.2 High Efficiency Motors

- A. High efficiency motors are basically high flux density, low core loss, and low current density motors, which shall be employed whenever applicable.
- B. Minimum efficiency performance requirement (MEPR) for electric motors used in residential, commercial, and institutional applications in these guidelines shall be at least IE2 type or whatever minimum energy performance requirement mandated by the DOE. The goals of implementing MEPR are to increase energy efficiency, promote energy savings, and reduce operating cost for electric motors.

- C. Exceptions to the MEPR are the following:
1. Submersible motors;
 2. Motors that are integrated into a system that prevents the individual motor efficiency from being tested;
 3. Motors designed to operate at extremely high or low temperatures, in explosive environments (ATEX), or at altitudes above 1000 meters above sea level.
- D. The latest versions of IEC 60034-2-1 – Standard for electric motors and IEC 60034-30-1 – Classification scheme comprising four levels of motor efficiency ("IE-code") shall be the reference standards used in these guidelines. On the other hand, the latest edition of NEMA MG 1, which defines the manufacturing standards for alternating-current (AC) and direct-current (DC) motors shall also be the reference standard to be used in these guidelines.
- E. IEC 60034-30-1 is the standard for electric motors, where IE1 (Standard Efficiency), IE2 (High Efficiency), IE3 (Premium Efficiency) and IE4 (Super Premium Efficiency) are the energy efficiency types or classification. IE4 motors are higher in efficiency than IE3 motors, which are more efficient than IE2 motors, and so on.
- F. For cooling systems using motors, either the Energy Efficiency Factor (EEF) or the Cooling Seasonal Performance Factor (CSPF) shall be the measure of energy performance that shall apply. EEF shall apply to refrigeration systems, while CSPF shall apply to air conditioning systems. The higher the EEF or CSPF, the higher the system's efficiency. Please refer to the Mechanical Systems Section for the Minimum Energy Performance (MEP) requirements for refrigerating and air conditioning systems, as mandated by DOE.

8.3 Starting and Control Methods for Electric Motors

A. Starting Methods

1. Direct-on-line is the most basic and simplest starting method. Although the starting time is short, the torque at starting is smaller and the current is large, which is suitable for starting small capacity motors only.
2. Star-Delta Method is a three-phase induction motor whose stator winding is stipulated to link in delta connection. It can be started in star to reduce the starting current and then closes at delta coil connections. Star-Delta starting shall be avoided.
3. Auto-transformer starting refers to a reduction of grid voltage to the motor stator windings until the speed approaches to a steady value, and then the motor is connected to the power grid. Transformer tapping is chosen to receive required starting voltage and starting torque. This device shall be avoided unless extremely necessary.
4. Soft Starting method includes soft starting light load efficiently. One of the most important features is that the electronic circuit is conducted into the silicon-controlled rectifier of the motor under the tandem connection of power supply. The torque of the motor gradually increases with enhancing speed. Soft starter is a voltage regulator that only changes the voltage without altering the frequency at starting. This method is highly recommended for most applications. Soft starters with energy optimization shall be used in all simple constant speed operation to ensure high efficiencies and high power factors even during light duty conditions without reduction in speed.

B. Variable Speed/Frequency Drives

1. Variable Speed Drive (VSD) or Variable Frequency Drive (VFD) describes the equipment used to control the speed of machinery by changing the frequency of the motor that is being operated. Where process conditions demand adjustment of flow from a pump or fan, varying the speed of the drive shall save energy compared with other techniques for flow control.
2. VSD/VFD provides many benefits to motor operation such as smooth starting, smooth acceleration and deceleration time, stopping methods, reversal of motor, increased power factor, and huge savings if properly applied. It is highly recommended in most applications requiring variable speed operation.
3. Variable frequency/speed drives produce harmonics. It is very important that the VFD is designed according to advanced technology; having improved VFD switching devices, harmonic filters, topologies, simulation control techniques, and effective control of software and hardware devices in order to ensure that the Total Harmonic Distortion (THD) shall be kept below 5%. The building is best to have an on-line power quality monitoring device.
4. Throttling control of fans is easily done by the use of VFD resulting to substantial energy reduction. All blower and fans requiring speed control operation shall use variable frequency drives.
5. For most efficient operations, buildings shall be equipped with servo motors or VFD-driven motors instead of conventional electro-mechanical devices.

6. All motors for mechanical equipment over five (5) kW shall utilize high efficiency motors (at least IE2), in accordance with *Table 43*, coupled with variable speed drives (for variable speed applications) or soft starters (for constant speed applications).
7. All motors of cooling towers shall utilize high efficiency motors (at least IE2), in accordance with *Table 43* coupled with variable speed drives (for variable speed applications) or soft starters (for constant speed applications).
8. Kitchen ventilation fans are exempt from this requirement. Non-centralized air-conditioning systems in buildings are not required to employ variable speed controllers. However, said fans and air-conditioning systems shall comply with the MEPP mandated by DOE.

8.4 DC Motors

- A. Use DC motors for applications of higher starting torque, quick starting and stopping, reversing, and variable speeds with voltage free from harmonics.
- B. DC motor principles are used in tools, toys, and appliances. The universal motors are lightweight brushed motor used for portable power tools and other applications.
- C. Brushless DC (BLDC) motors produce comparatively low operating noise as compared with other motors with the same ratings. BLDC motors can have a feedback control to monitor and control the speed and torque, resulting to accurate torque and speed control providing higher efficiency, low power consumption, and long battery life where batteries are needed.
- D. Unless extremely necessary, use of large DC motors shall be avoided.

8.5 DC Motors with Inverters (DC Drives)

- A. DC Drives further strengthens the advantage of DC motors over AC motors. Losses from electro-mechanical components are replaced with low loss static components.
- B. Brushless DC motors and other inverter-driven DC motors are preferred over other AC motors controlled by electro-mechanical devices.
- C. Efficiency is further enhanced in multiple DC operations using common DC bus drive systems. Cost savings are possible because only one larger system is used for many smaller reactors, braking units, contactors, etc.
- D. Due to its low energy consumption and very good speed control capabilities, DC motors with inverter drives are used now in many applications, such as inverter type air conditioners, inverter type refrigerators and inverter type escalators/walkways.
- E. In all of the above methods, compliance with specific PEC provisions on proper sizing of control components and protective devices shall be observed.

8.6 Pumps

- A. Pump nameplate shall cover all electrical parameters and mechanical information. Ensure that the suction and discharge dimensions are correctly applied for maximum performance. Non-compliance of actual installation to pump capacity shall be rejected.
- B. A pump shall be properly sized for its application to attain a flow near peak efficiency maintaining a flow between 80% and 100% of the Best Efficiency Point (BEP).

- C. Improperly sized pumps operate too far off the BEP, and forces an imbalance inside the pump, resulting to parts failure due to excessive wear. Operating to the right of the BEP increases the exit velocity of the fluid leaving the pump. When the discharge flow is restricted, fluid re-circulates within the pump, creating a low-pressure area which can lead to increased radial loading and low flow circulation. These conditions substantially degrade the efficiency performance of the pumps and shall be avoided.
- D. The creation of imbalanced pressure increases the radial loads on the impeller and would cause shaft deflection. This increases vibration which damages the bearing and or mechanical seals, all resulting to poor performance and shall be avoided.
- E. If the Net Positive Suction Head (NPSH) is too low, the fluid pressure on the trailing side of the fluid forms vapor bubbles, which can collapse violently. This can cause sudden, dangerously uneven axial and radial loading on the impeller. A digital monitoring system with data acquisition, analysis, and control would be effective in avoiding such conditions. A Predictive Maintenance program plays a major role in increasing the life of a pump.
- F. Where an application requires varying output operation of motor-driven equipment such as a centrifugal pump, a variable frequency/speed drive shall be used, instead of throttling the output of the pump.
- G. All buildings with at least ten (10) storeys shall include in the water distribution system the integration of overhead or elevated water tanks that will facilitate the distribution of potable and/or non-potable water into the building spaces, without compromising the required water volume and pressure, provided that there is a twenty percent (20%) fire reserve over and above the average daily demand supply. The system shall rely mostly on elevation and gravity to distribute water within the building in order to reduce dependence on pumps and motorized systems, thus reducing energy consumption.

- H. All motors for domestic pumps shall utilize high efficiency motors with at least IE2 ratings (refer to *Table 43*) and be equipped with either soft starters (for constant speed applications) or VFDs/VSDs (for variable speed applications).

8.7 Escalators and Walkways

- A. Escalators and moving ramps/walkways shall be fitted with automated controls to reduce to a slower speed when no activity has been detected for a maximum period of one and a half (1½) minutes, where the duration may be adjusted depending on the demand.
- B. Escalators and moving ramps/walkways shall automatically be placed on standby mode when no activity has been detected for a maximum period of five (5) minutes; duration may be adjusted depending on the demand.
- C. Escalators and moving ramps/walkways shall be designed with energy-efficient AC motors equipped with VFDs or DC inverter drives. Activation of reduced speed and power off and power on modes shall be done through sensors installed under the top or bottom landing areas.
- D. Escalators with high gravitational potential energy (i.e., high-capacity escalators moving many people with long downward travel distances), especially for airports and train stations, shall be equipped with VFDs/VSDs coupled with line regenerative drives.

8.8 Elevators/Lift

- A. Elevators shall use alternating current (AC) Variable Voltage and Variable Frequency (VVVF) drives on non-hydraulic elevators to reduce energy demand.

- B. Elevators of buildings with at least ten storeys, especially office buildings and hotels, shall be equipped with VFDs/VSDs coupled with line regenerative drives.
- C. Elevators shall use energy-efficient lighting, including on displays in the elevator car, which shall have an average lamp efficacy, across all fittings in the car, of at least 80 lumens/watts.
- D. All lighting, except the emergency light powered by the UPS of the building, shall switch off after the elevator has been inactive for a maximum period of five (5) minutes.
- E. The elevators shall operate in a standby mode when no activity has been detected for a maximum period of five (5) minutes; said duration may be adjusted, depending on the demand.

8.9 Required Design Documentation

The following documents shall be required for the building permit application:

- A. Architectural floor plans showing the location of elevators, escalators, moving ramps and walkways, and pumps
- B. Building sections showing the height and vertical location of the elevators, escalators, moving ramps, and walkways
- C. Electrical plans showing single line diagrams of power supply, manual and automatic control circuits, load schedule and technical specifications of all motor-driven equipment, especially the energy efficiency types/classification of the motors.
- D. Mechanical equipment schedule showing the description of operation of the elevators, escalators, moving ramps and walkways, and pumps

- E. Technical data sheets/brochures of VFDs/VSDs, line regenerative drive equipment, elevators, escalators, moving ramps/walkways, and pumps
- F. Process control diagrams of elevators, escalators, and moving ramps/walkways
- G. Relevant drawings and plans.

Section IX. Electric Power and Distribution

9.1 Scope

This section applies to the energy efficiency requirements for transformers and energy conservation requirements of the distribution systems of buildings.

9.2 Transformer

- A. All transformers that are to be part of the building's electrical system shall have efficiencies not lower than 98%. The transformer shall be tested in accordance with the latest edition of the relevant Philippine National Standards (PNS), under the test conditions of full load, free of harmonics, and at unity power factor.
- B. The average power factor of the loads being served by the transformers at any time shall not be less than 85% lagging. In cases where load power factors are below this value, capacitors or power factor improving devices shall be provided so that automatic or manual correction can be made. When capacitor banks are installed and the Computed Harmonic Contamination Index (CHCI) of a building surpasses 15%, the capacitor bank shall be equipped with detuned filters. CHCI shall be computed by the following formula:
$$\text{CHCI} = \text{kW (harmonic loads)}/\text{kW (total load)} \times 100$$
- C. Transformer load grouping schemes shall be so designed such that the transformer is loaded to not less than 60% of its full load ratings, and that no-load circuits or partially loaded circuit combinations shall be minimized as much as possible.

- D. Disconnect switches or breakers shall be provided at the primary (supply) side of the transformer to allow electrical disconnection during no load period.
- E. Transformers located inside a building shall have sufficient ventilation and have direct access from the road for ease of maintenance at all times.
- F. The high voltage side of the main transformer shall be connected in delta, while the low voltage side shall be connected in wye with its neutral available for grounding.

9.3 Power Supply and Distribution

- A. In the calculation of the wire sizes to be used, the designer shall follow the procedure specified in the latest edition of the Philippine Electrical Code (PEC), Part I, considering the factors stated therein so as to arrive at the minimum acceptable wire size.
- B. The design Total Harmonic Distortion (THD) and Total Demand Distortion (TDD) for a three-phase circuit at the connection point in the distribution system shall not exceed the limits specified in the Philippine Distribution Code (PDC).
- C. For three-phase, four-wire circuits with single-phase loads, the maximum current unbalance (unbalance single-phase loads distribution) shall not cause the voltage unbalance at the distribution system to exceed the limits specified in the Philippine Distribution Code.
- D. All buildings shall install systems to protect their facilities from the effects of lightning and transient voltage surges, which complies with the relevant provisions in the latest edition of the PEC Part 1.

- E. Electrical vaults/rooms, switchgear rooms, generator rooms, indoor substations, control rooms, relay rooms, battery rooms, metering rooms, SCADA and Telecommunications rooms, and other similar rooms, shall have sufficient natural or mechanical ventilation to keep the room temperatures below 30°C and the relative humidity at 75-95% non-condensing.
- F. The sum of the operating cost over the economic life of the distribution system (Life Cycle Cost) shall be considered rather than just the initial cost. Operating cost shall include, but is not limited to, the maintenance cost and energy losses.

G. Electric Vehicle (EV) Parking with Charging Stations

1. Private and public buildings and establishments covered by these guidelines and pursuant to Republic Act No. 6541, otherwise known as the National Building Code of the Philippines, shall designate dedicated parking slots for the exclusive use of Electric Vehicles (EVs). The number of dedicated parking slots shall be proportional to the total number of parking slots within the building or establishment as mandated by said law.
2. All designated EV parking areas shall be provided with charging stations or electric vehicle supply equipment (EVSE) for use in charging the EVs. Construction of the EVSE shall comply with all the relevant local standards for electrical connection.
3. The installation of the EVSE is made cost-effective when the infrastructure is installed during the initial construction phase as opposed to retrofitting existing buildings to accommodate the new electrical equipment. EVSEs that are installed close to the required power source reduce the need for cutting, trenching, and drilling to add new conduits to reach the EVSE. Additionally, the cost of installation can be reduced if the existing conduits have adequate capacity for EVSEs.

4. The installation of a separate meter or sub-metering allows electricity used by EVSE to be isolated from the rest of a building or structure’s energy usage, though distinguishing usage between multiple cords of an EVSE can only be accomplished by the EVSE itself. For locations with multiple EVSE, it is best practice to provide a separate meter for each.
5. The raceway(s) shall originate at a service panel or subpanel(s) serving the area, and shall terminate in close proximity to the proposed location of the charging equipment and into listed suitable cabinet(s), box(es), enclosure(s), or equivalent. Plan design shall be based on 40-ampere minimum branch circuits.

H. Uninterruptible Power Supply (UPS) System

1. All buildings with at least ten (10) storeys shall have a UPS System with enough capacity to power the emergency/ security lighting load of all the corridors, emergency exits, stairwells, elevators, parking spaces, and perimeter areas of a building for at least one (1) hour (back-up time).
2. The UPS System to be installed in the building shall be of the most efficient design/configuration for the capacity required. Please refer to *Table 44*.
3. The total harmonics generated by the UPS System shall not exceed 5%.

Table 44: Types and Characteristics of Uninterruptible Power Supply (UPS) Systems

Classification	Practical Power Range (kVA)	Voltage Conditioning	Cost per VA	Efficiency	Inverter always operating
Standby	0 – 0.5	Low	Low	Very High	No
Line Interactive	0.5 – 5	Design Dependent	Medium	Very High	Design Dependent
Standby On-Line Hybrid	0.5 – 5	High	High	Low	Partially
Standby Ferro	3 – 15	High	High	Low	No
Double Conversion On-Line	5 – 5000	High	Medium	Low	Yes
Delta Conversion On-Line	5 – 5000	High	Medium	High	Yes

Source: ENPAP 4.0

Notes: Descriptions of the UPS classifications can be seen in the Definition of Terms Section

I. Emergency/Standby Generator Sets

1. Buildings with elevators are required to have emergency generator sets with enough capacities to power the elevators for a limited duration (i.e., enough time to evacuate persons trapped inside the elevators) during commercial power outages.
2. The generator set shall be sized to its proper power rating to maximize its use and efficiency. The rating is defined as follows:
 - a. Standby Power Rating – Standby power rated generators are the most commonly rated generator sets. Their primary application is to supply emergency power for a limited duration during a power outage.

Standby power rating shall be applied to the unit where public utility power is available. The typical rating for a standby engine shall be sized for a maximum of 80% average load factor, and roughly 200 hours per year. This includes less than 25 hours per year of running time at the standby rating.

- b. Prime Power Rating – Prime power rated generators shall be used in applications where the user does not purchase power from a public utility. The prime power rating is the maximum power available for an unlimited number of hours per year in a variable load setting. It is not advisable that the variable load exceed 70% of the average prime power rating during any operational period of 250 hours. If the engine is running at 100% prime power, yearly hours shall not exceed 500. Prime power is accessible for a limited number of hours in non-variable load situations. Limited prime power is intended for circumstances where power outages are expected, such as a planned utility power reduction. Engines in generator sets may operate up to 750 hours per year at power levels less than the maximum prime power rating. In these situations, it is important to never exceed the prime power rating.
 - c. Continuous Power Rating – Continuous power rating is used in applications where supplying power is at a constant 100% load for an unlimited number of hours each year. Continuous power rated units are most widely used in applications where the power grid is unreachable or unreliable. Such applications include mining, agriculture or military operations.
3. For buildings with ten storeys or higher, an automatic transfer switch (ATS) shall be installed to transfer the power source from the usual local power utility to the emergency/back-up power source, after a short delay, during commercial power interruptions.

4. The generator set's fuel consumption at 100% rated capacity shall not go over 0.28 liters per kWh. Accordingly, every generator set shall be equipped with fuel flow meter and electric power meter.

J. Metering for Energy Auditing

1. Covered buildings shall have metering facilities capable of measuring voltage, current, power factor, power quality, maximum demand, and energy consumption. In addition, it shall have provision for feeder metering facilities.
2. Where possible, a feeder circuit shall serve only a particular group of loads sharing the same function for better monitoring and control. These loads can be grouped as follows:
 - a. Lighting Load
 - b. Chiller
 - c. Air Handling Units, Unitary Air Conditioning Systems
 - d. Other Motor Loads (exhaust fan, pumps, etc.)
3. Energy meters and instrument transformers utilized for billing purposes shall have an accuracy class rating of at least 0.5. Otherwise, such devices shall have an accuracy class rating of at least 1.0.
4. In multiple tenant buildings, each tenant unit shall have a provision for measuring the tenant's energy consumption. Power for common utilities such as water pump, elevator, etc. shall also be metered.
5. In order to facilitate metering safely and quickly by qualified personnel, an adequate working space in front of the electrical panels and meters shall be provided.

9.4 Building Management System

- A. Buildings are encouraged to install Building Management Systems (BMS) to have centralized monitoring and control of the many individual systems within the building, such as, but not limited, to the following:
1. HVAC system
 2. CCTV system
 3. Security system
 4. Lighting system of common areas
 5. Smoke and fire alarm system
 6. Elevator system
 7. Emergency power supply system
 8. Alternative power supply system
 9. Smart garden system
 10. Energy monitoring system
 11. Indoor air quality system
 12. Public address system
 13. Communication system
- B. BMS with analytics and optimization software can realize significant energy savings for a building.
- C. BMS with internet connections shall be protected by a firewall to prevent hackers from entering the system.

9.5 Smart Home System

- A. Residential dwelling buildings, such as condominiums, are encouraged to employ smart home technologies in every home unit, which shall be equipped with sensors, devices and appliances that are connected to the Internet of Things (IoT) and are able to be remotely monitored, controlled and accessed by the home owner.

Any or all of the following may be utilized towards this end:

1. Lighting control system
 2. Smart lamps/light bulbs
 3. HVAC control system
 4. Home security such as CCTV, burglar alarm, etc.
 5. Security access such as smart door locks
 6. Home energy monitor
 7. Smart appliances such as refrigerators, laundry machines, coffee maker, TV, radio, etc.
 8. Smart devices such as smoke detector, etc.
 9. Smart garden irrigation
 10. Other similar systems
- B. Smart home systems shall be protected from possible hackers through the use of hardware and/or software solutions.

9.6 Regular Inspection, Maintenance, and Audit

- A. Buildings shall conduct annual inspection and maintenance of their electrical systems, such as thermal scanning of the transformers, panel boards and conductors to check for hot spots, which are sources of losses in a distribution system and, at the same time, possible causes of electrical fires.
- B. Buildings, at the onset of operation, shall monitor and record their monthly energy consumption in order to establish a baseline value.
- C. Covered buildings shall conduct regular energy audit of their facilities.

9.7 Required Design Documentation

The following documents shall be required for the building permit application:

- A. Electrical plan showing the power supply layout and single line diagrams of the building's connection to the local power utility supply, the internal distribution system, transformer, protection, metering, and back-up (e.g., emergency gensets) and alternative power systems (e.g., RE power supply system), containing, among others, the load schedule, calculations, technical specifications and other details required by the latest edition of the PEC Part 1.
- B. The electrical plan shall show the UPS supplied circuits, particularly for emergency lighting.
- C. Design drawings, calculations, and technical specifications of the lightning protection system and surge suppression/protection system.
- D. Brochures and technical data sheets of main transformer, protection, metering, UPS, emergency generator sets, lightning protection system, and surge suppression system.
- E. Building plans and specifications shall include, but are not limited to, the following:
 1. The type and location of the EVSE
 2. The design of the raceway(s)
 3. Electrical calculations to substantiate the design of the EV supply system, to include the rating of equipment and any on-site distribution transformers to ensure sufficient capacity to simultaneously charge all required EVs at full-rated amperage.

Section X. Renewable Energy (RE) Systems and Equipment

10.1 RE Power Supply Systems

- A. Buildings shall install RE power supply systems within their facility, whenever it is technically feasible, either at their rooftops, façades, grounds and/or roofed parking spaces to reduce demand, energy costs, and, indirectly, reduce greenhouse gas (GHG) emissions.
- B. RE power supply system capacity can be sized to either supply partially the energy requirements of the facility (own use), or supply entirely the energy requirements of the facility (Net Zero Energy Building) or, aside from satisfying its own power requirements, sell the excess energy to the local power utility (Net Metering, which, presently, is up to 100 kW only but may be raised by ERC in the future).
- C. RE power supply systems shall be designed and installed in accordance with the relevant provisions of the latest editions of the Philippine Electrical Code Part 1, the Philippine Distribution Code, applicable rules and regulations issued by ERC and the Office of the Building Official and by the rules and interconnection procedures established by the local distribution utility under which franchise the building is covered.
- D. Buildings are encouraged to use systems or equipment that utilize RE, such as solar photovoltaic (PV) and/or wind power supply systems, solar water heaters, solar air conditioners, solar powered lighting systems, and the like, whichever is applicable, to reduce demand for commercial power.
- E. Solar PV power supply systems shall employ either grid tie inverters or hybrid inverters, equipped with active harmonic filters and surge protection. Grid tie inverters need the grid voltage to synchronize in order to start generating power.

Hence, when there is a commercial power interruption, the solar PV power supply system also shuts down for safety reasons. Therefore, grid tie inverters are not able to do islanding operation. On the other hand, hybrid solar inverters are more flexible and can support not only commercial power but multiple power sources, such as battery system, gasoline/diesel generator sets, etc. and, therefore, are able to operate on island mode. However, hybrid inverters are more costly than grid tie inverters. In places where the commercial/utility power supply is unreliable (i.e., frequent and/or long power interruptions), hybrid inverters shall be used to achieve resiliency.

- F. RE power supply systems shall be equipped with at least two (2) meters; one measuring, among others, the quantity of RE power being supplied to the building, and the other measuring the quantity of commercial power (i.e., from the local electric utility) being supplied to the building.
- G. In evaluating the economic feasibility of RE power supply systems and equipment, Life Cycle Cost or Cost of Ownership shall be considered and not the initial cost only.
- H. Buildings, being end users of electricity, are encouraged to avail of the Green Energy Option Program (GEOP) and demand from their local electric utility/cooperative or Retail Electricity Supplier (RES) that the energy to be supplied to the building shall be from RE sources to avail of the incentives under R.A. 9513 (Renewable Energy Act).

10.2 Annual Energy Requirements from RE

- A. Covered buildings shall source, initially, a minimum of one percent (1%) of their projected annual energy requirements (i.e., same level as the RPS) to reduce demand for commercial power through the installation of any or a combination or all of the following:

1. Re power supply systems
2. Solar water heaters
3. Solar cooling systems
4. Solar-powered lighting systems
5. Any other similar system or equipment

- B. Availing of the GEOP by a building shall also satisfy the above stated requirement (i.e., in A.)
- C. The above requirement (in A.) may be increased by the DOE from time to time, in accordance with its mandate.

10.3 Required Design Documentation

The following documents shall be required for the building permit application:

- A. Electrical plan showing the power supply layout and single line diagram of the building's connection to the local power utility supply, the internal distribution system, protection, metering, and back-up (e.g., emergency gensets) and alternative power systems (e.g., RE power supply system), showing the technical specifications of the protection, metering, emergency generator sets, and RE power supply system (whichever is applicable)
- B. Brochures and technical data sheets of the main components of the RE power supply system (if applicable)
- C. Electricity power supply contract.

APPENDICES

Appendix A: Obligations of Building Owners

- A. Integrate an energy management system policy into the business operation based on ISO 50001 or any similar framework;
- B. Set up programs to develop and design measures that promote energy efficiency, conservation, and efficiency that may include installation and/or utilization of renewable energy technologies or sources;
- C. Set up annual targets, plans, and methods of measurements and verification for the implementation of energy efficiency and conservation projects;
- D. Keep records on monthly energy consumption data and other energy-related data;
- E. Improve average specific energy consumption in accordance with the annual reduction targets to be established by the DOE in the NEECP;
- F. Submit an annual ECCR to the DOE by April 15 every year;
- G. Conduct an energy audit once every three (3) years, by engaging either a certified energy auditor or an accredited ESCO, and submit an energy audit report to the DOE upon completion of the energy audit;
- H. Employ a CECO for Type 1 establishments, and a CEM for Type 2 designated establishments; provided, that the CECO and the CEM may be chosen from within the organization or hired through external recruitment; and
- I. Duly notify the DOE on the appointment or separation from the service of their respective CECOs or CEMs within ten (10) working days from the effective date of these personnel actions.

Appendix B: Sample Calculations for Overall Thermal Transfer Value (OTTV)

Calculation for Wall OTTV:

Facade Name	Name	Area [M ²]	WWR [-]	U-Value [W/m ² K]	T _{deq} /dT _i [K]	SHGC Glazing [-]	SC Shading [-]	Facade Orientation		Sol.Cor. Factor [-]	OTTV [W/m ²]
								Slope[°]	Orientation		
Light concrete wall, single glazing, no shading	wall	80.0	20%	1.504	10	0.72	None	Slope[°]	90	1.25	40.9
	window	20.0		5.500	5			Orientation	E		
Light concrete wall, single glazing, with external shading	wall	30.0	70%	1.504	10	0.54	Horizontal	Slope[°]	90	1.25	40.0
	window	70.0		4.000	5			Orientation	E		
Fully glazed building, with no shading	wall	20.0	80%	0.626	15	0.27	None	Slope[°]	90	1.25	43.0
	window	80.0		1.500	5			Orientation	E		
Low energy building	wall	40.0	60%	0.626	15	0.27	Horizontal	Slope[°]	90	1.25	17.5
	window	60.0		1.500	5			Orientation	E		

Source: EU –ASEP, 2020

Appendix B (Continued)

Calculation for Roof OTTV:

Roof Name	Name	Area [M ²]	WWR [-]	U-Value [W/m ² K]	T _{deq} /dT _i [K]	SHGC Glazing [-]	SC Shading [-]	Facade Orientation		Sol.Cor. Factor [-]	OTTV [W/m ²]
								Slope[°]	Orientation		
Insulated concrete roof	insulated roof	100.0	0%	0.600	16	0.00		Slope[°]	0	1.00	9.6
	skylight	0.0		0.000	5			Orientation	S		
Insulated metal roof	insulated roof	00.0	0%	0.600	16	0.00		Slope[°]	0	1.00	9.6
	skylight	0.0		0.000	5			Orientation	S		
Insulated concrete roof with skylight	insulated roof	90.0	10%	0.600	16	0.72		Slope[°]	0	1.00	34.4
	skylight	10.0		5.500	5			Orientation	S		
Insulated concrete roof with atrium	insulated roof	60.0	40%	0.600	16	0.27		Slope[°]	0	.00	143.3
	skylight	40.0		1.500	5			Orientation	S		

Source: EU –ASEP, 2020

Appendix C: Percentage of Solar Radiation Absorbed by Selected Building Materials

Building Material	Percentage (%)
Brick (common)	
Light red	55
Red	68
Marble	
White	44
Dark	66
Polished	50-60
Metals	
Steel	45-81
Galvanized iron, new	64
Galvanized iron, dirty	92
Copper, polished	18
Copper, tarnished	64
Lead sheet, old	79
Zinc, polished	46
Paints	
White emulsion	12-20
White paint, 4.3 mm on aluminum	20
White enamel on iron	25-45
Aluminum oil base paint	45
Gray paint	75
Red oil base paint	74
Black gloss paint	90
Green oil base paint	50
Black paint, 4.3 mm on aluminum	94-98
Roofing materials	
Tile clay, red	64
Tile	65-91
Miscellaneous	
Aluminum, polished	15
Concrete	60
Concrete, rough	60
Plaster, white wall	7
Wood	60
Aluminum foil	15

Appendix C (Continued)

Building Material	Percentage (%)
Ground Cover	
Asphalt pavement	93
Grass, green after rain	67
Grass, high and dry	67-69
Sand, dry	82
Sand, wet	91
Sand, white powdered	45
Water	94
Vegetable fields and shrubs, wilted	70
Common vegetable fields and shrubs	72-76
Ground, dry and plowed	75-80
Bare moist ground	90

Where specific material is not mentioned above, an approximate value may be assigned with the use of the following color guide:

Color	(%) Absorption
White, smooth surfaces	25-40
Gray to dark gray, light green	40-50
Green to dark green, red, brown	50-70
Dark brown, blue	70-80
Dark blue, black	80-90
Perfectly black	~100
Sand, wet	91
Sand, white powdered	45
Water	94
Vegetable fields and shrubs, wilted	70
Common vegetable fields and shrubs	72-76
Ground, dry and plowed	75-80
Bare moist ground	90

Note: All asbestos in building material shall be omitted to apply fiber cement board.

Appendix D: Thermal Conductivities of Building Materials

Construction Materials	Density (kg/m ³)	Thermal Conductivity (W/m ² ·K)
asphalt, roofing	2240	1.226
Bitumen		1.298
Brick		
(A) common	1925	0.721
(B) face	2085	1.297
Concrete	2400	1.442
	64	0.144
Concrete, light weight	960	0.303
	1120	0.346
	1280	0.476
Cork board	144	0.042
Fiber board	264	0.052
Fiber glass (see glass wool and mineral wool)		
Glass sheet	2512	1.053
Glass wool, mat or guilt (dry)	32	0.035
Gypsum plaster board	880	0.170
Hard board		
(A) standard	1024	0.216
(B) medium	640	0.123
Metals		
(A) aluminum alloy, typical	2672	211
(B) copper, commercial	8794	385
(C) steel	7840	47.6
Mineral wool, felt	32–104	0.032–0.035
Plaster		
(A) gypsum	1216	0.370
(B) perlite	616	0.115
(C) sand/cement	1568	0.533
(D) vermiculite	640–960	0.202–0.303
Polystyrene, expanded	16	0.035
Polyurethane, foam	24	0.024
PVC flooring	1360	0.713
Soil, loosely packed	1200	0.375
Stone, tile		
(a) sandstone	2000	1.298
(b) granite	2640	2.927
(c) marble/terrazzo/ceramic/mosaic	2640	1.298
Tile, roof	1890	0.836
Timber		
(a) across grain softwood	608	0.125
(b) hardwood	702	0.138
(c) plywood	528	0.138
Vermiculite, loose granules	80–112	0.065
Wood chipboard	800	0.144
Woodwool slab	400	0.086
	480	0.101

Appendix E: K-Values of Basic Materials

Construction Materials	Density (kg/m ³)	Thermal Conductivity (W/m ² ·K)
Asbestos cement sheet	1488	0.317
Asbestos insulating board	720	0.108
asphalt, roofing	2240	1.226
Bitumen		1.298
Brick		
(a) dry (covered by plaster or tiles outside)	1760	0.807
(b) common brickwall (brickwall directly exposed to weather outside)	1760	1.154
Concrete	2400	0.1442
	64	0.144
Concrete, light weight	960	3.303
	1120	0.346
	1280	0.476
Cork board	144	0.042
Fiber board	264	0.052
Fiber glass (see glass wool and mineral wool)		
Glass sheet	2512	1.053
Glass wool, mat or guilt (dry)	32	0.035
Gypsum plaster board	880	0.170
Hard board		
(a) standard	1024	0.216
(b) medium	640	0.123
Metals		
	6272	211
	8784	385
	7840	47.6
Mineral wool, felt	32–104	0.035–0.032
Plaster		
(a) gypsum	1216	0.370
(b) perlite	616	0.115
(c) sand/cement	1568	0.533
(d) vermiculite	640–960	0.202–0.303
Polystyrene, expanded	16	0.035
Polyurethane, foam	24	0.024
PVC flooring	1360	0.713
Soil, loosely packed	1200	0.375

Appendix E (Continued)

Construction Materials	Density (kg/m ³)	Thermal Conductivity (W/m-°K)
Stone tile		
(a) Sand stone	2000	1.298
(b) Granite	2640	2.927
(c) Marble/terrazzo/ceramic/mosaic	2640	1.298
	1890	0.836
Tile, roof		
Timber		
(a) Across grain softwood	608	0.125
(b) Hardwood	702	0.138
(c) Plywood	528	0.138
Vermiculite, loose granules	80–112	0.065
Wood chipboard	800	0.144
Woodwool slab	400	0.086
	480	0.101

Appendix F: Air Space Resistances for Walls and Roofs

Types of Air Space	Thermal Resistance (M ² -°C/W)		
	5 mm	20 mm	100 mm
Air space resistance (R _a) for Walls			
Vertical air space (Heat flows horizontally)			
(a) High Emissivity	0.110	0.148	0.160
(b) Low Emissivity	0.250	0.578	0.606
Air Space Resistance, (R _a) for Roof			
Horizontal or sloping air space (Heat flows downward)			
(a) High Emissivity			
(i.) Horizontal air space	0.110	0.148	0.174
(ii.) Sloped air space 22.5°	0.110	0.148	0.165
(iii.) Sloped air space 45°	0.110	0.148	0.158
(b) Low Emissivity			
(i.) Horizontal air space	0.250	0.572	1.423
(ii.) Sloped air space 22.5°	0.250	0.571	1.095
(iii.) Sloped air space 45°	0.250	0.570	0.768
Attic Space Resistances (R _{attic})			
(a) High Emissivity		0.458	
(b) Low Emissivity		1.356	

Notes:

1. Ordinarily, high emissivity is assumed for air spaces bounded by building materials of moderately smooth surfaces. Low emissivity only applies where one or both sides of the air space is bounded by a reflective surface such as that of an aluminum foil.
2. Interpolation within the range of pitch angles from horizontal to 45° is permitted. For angle beyond 45°, the value for 45° can be used; no extrapolation is needed.
3. Interpolation within the range of thickness from 5 mm to 100 mm is permitted. For air space less than 5 mm, extrapolation basing on R_a = 0 for zero thickness is allowed; otherwise R is assumed to be zero. For air space greater than 100 mm, the R_a for 100 mm should be used, i.e. extrapolation is not permitted.
4. In the case of air space in roofs, reflective foil used should be installed within the reflective surface facing downward as dust deposit will render an upward-facing surface ineffective after a while.

Appendix G: Surface Film Resistances

Types of Air Space	Thermal Resistance (m ² -°C/W)
Walls	
Inside surface	0.12
Smooth finishes	0.30
Reflective finishes	0.04
Outside surface	
Roots	
Inside surface	0.16
Flat (smooth finish)	0.15
45° sloped (smooth finish)	0.80
Flat (reflective finish)	0.39
45° sloped (reflective finish)	
Outside surface	0.56
Flat or sloped	

Note: Interpolation between angles of slope from horizontal to 45° is valid.

Appendix H: Glass Thermal Transmittance Values

Glass Type	U-Value (Glass only) (W/m ² -°C)	
	Exposed	Sheltered
Flat glass	5.91	4.60
Single pane, clear		
Single pane, with low emittance coating		
e = 0.60	5.68	4.54
e = 0.40	5.11	3.97
e = 0.20	4.26	3.12
Insulating glass		
Double pane, clear		
4.8 mm air space	3.69	3.29
6.4 mm air space	3.46	3.12
12.5 mm air space	3.18	2.95
Double pane, with low emittance coating		
e = 0.60	3.01	2.78
e = 0.40	2.67	2.44
e = 0.20	2.21	2.04

To account for outside or inside sashes/frames, the following correction factors shall be used:

Glass Type	Correction Factors			
	Inside		Outside	
	Exposed	Sheltered	Exposed	Sheltered
Single pane				
Clear	0.46	0.60	0.48	0.60
Low e	0.50	0.56	0.65	0.77
Double pane				
Clear	0.64	0.65	0.65	0.66
Low e	0.71	0.70	0.80	0.98

Appendix I: Glass Performance Data

Glass Type		Monolithic	Monolithic
Code		FL	FL
Color		Clear	Clear
Thickness		15 mm	19 mm
Substrate		None	None
Visible Light, %			
Transmittance	TV	83.10	81.70
Reflectance, out	RV	8.80	8.70
Reflectance, in	RV'	8.80	8.70
Solar Energy, %			
Transmittance	TE	68.10	62.90
Reflectance, out	RE	7.60	7.20
Reflectance, in	RE'	7.60	7.20
Absorptance	AE	24.40	29.90
Shading Coefficient	SC	0.85	0.81
U-value, Summer W/m ² -°K	U	5.70	5.63
U-value, Winter W/m ² -°K	UW	6.05	5.89
Solar heat gain coefficient	SHGC	0.74	0.70
Relative heat gain W/m ² -°K	RHG	582	554

Note:

1. Above data is on monolithic substrate only.
2. Calculation of U-value, Relative Heat Gain based on ASHRAE condition (GSBDL-GL)

Appendix J: Glass Performance Data

Glass Type	Clear-12	Dark Green-12	Bronze-12	Dark Blue-12
Code	FL	DNFL	BFL	DHFL
Color	Clear	Dark Green	Bronze	Dark Blue
Thickness	12 mm	12 mm	12 mm	12 mm
Substrate	None	None	None	None
Visible Light, %				
Transmittance	84.50	52.50	22.10	36.00
Reflectance, out	9.00	6.50	5.30	5.70
Reflectance, in	9.00	6.50	5.30	5.70
Solar Energy, %				
Transmittance	72.00	15.50	23.00	20.70
Reflectance, out	7.90	5.10	5.30	5.20
Reflectance, in	7.90	5.10	5.30	5.20
Absorptance	20.10	79.40	71.70	74.00
Shading Coefficient	0.89	0.43	0.49	0.47
U-value, Summer W/m ² -°K	5.75	6.29	6.23	6.25
U-value, Winter W/m ² -°K	6.17	6.17	0.43	6.17
Solar heat gain coefficient	0.77	0.37	0.47	0.41
Relative heat gain W/m ² -°K	603	320	358	346

Note:

1. Above data is on monolithic substrate only.
2. Calculation of U-value, Relative Heat Gain based on ASHRAE condition (GSBDLGL)

Appendix K: Glass Performance Data

Glass Type	Clear-10	Dark Green-10	Bronze-10	Dark Blue-10
Code	FL	DNFL	BFL	DHFL
Color	Clear	Dark Green	Bronze	Dark Blue
Thickness	10 mm	10 mm	10 mm	10 mm
Substrate	None	None	None	None
Visible Light, %				
Transmittance	85.60	57.50	27.90	42.00
Reflectance, out	9.10	6.80	5.40	6.00
Reflectance, in	9.10	6.80	5.40	6.00
Solar Energy, %				
Transmittance	75.10	20.70	28.90	26.50
Reflectance, out	8.00	5.20	5.50	5.40
Reflectance, in	8.00	5.20	5.50	5.40
Absorptance	16.90	74.00	65.60	68.10
Shading Coefficient	0.91	0.48	0.54	0.52
U-value, Summer W/m ² -°K	5.78	6.32	6.26	6.28
U-value, Winter W/m ² -°K	6.27	6.26	6.26	6.26
Solar heat gain coefficient	0.79	0.41	0.47	0.45
Relative heat gain W/m ² -°K	620	349	389	377

Note:

1. Above data is on monolithic substrate only.
2. Calculation of U-value, Relative Heat Gain based on ASHRAE condition (GSBDLGL)

Appendix L: Glass performance Data

Glass Type	Clear-8	Dark Green-8	Bronze-8	Dark Blue-8
Code	FL	DNFL	BFL	DHFL
Color	Clear	Dark Green	Bronze	Dark Blue
Thickness	8 mm	8 mm	8 mm	8 mm
Substrate	None	None	None	None
Visible Light, %				
Transmittance	86.50	62.90	35.30	48.90
Reflectance, out	9.20	7.20	5.70	6.30
Reflectance, in	9.20	7.20	5.72	6.30
Solar Energy, %				
Transmittance	77.90	27.80	36.30	33.80
Reflectance, out	8.20	5.40	5.70	5.60
Reflectance, in	8.20	5.40	5.70	5.60
Absorptance	13.90	66.70	58.00	60.50
Shading Coefficient	0.94	0.53	0.60	0.58
U-value, Summer W/m ² -°K	5.81	6.34	6.27	6.29
U-value, Winter W/m ² -°K	6.36	6.35	6.35	6.35
Solar heat gain coefficient	0.81	0.46	0.52	0.61
Relative heat gain W/m ² -°K	635	386	428	415

Note:

1. Above data is on monolithic substrate only.
2. Calculation of U-value, Relative Heat Gain based on ASHRAE condition (GSBDL-GL)

Appendix M: Glass Performance Data

Glass Type	Clear-6	Dark Green-6	Bronze-6	Dark Blue-6
Code	FL	DNFL	BFL	DHFL
Color	Clear	Dark Green	Bronze	Dark Blue
Thickness	6 mm	6 mm	6 mm	6 mm
Substrate	None	None	None	None
Visible Light, %				
Transmittance	87.50	68.90	44.70	57.00
Reflectance, out	9.20	7.60	6.10	6.80
Reflectance, in	9.20	7.60	6.10	6.80
Solar Energy, %				
Transmittance	80.50	37.40	45.60	43.20
Reflectance, out	8.60	5.80	6.20	6.00
Reflectance, in	8.60	5.80	6.20	6.00
Absorptance	10.90	56.90	48.30	50.70
Shading Coefficient	0.96	0.61	0.68	
U-value, Summer W/m ² -°K	5.82	6.33	6.25	6.28
U-value, Winter W/m ² -°K	6.44	6.44	6.44	6.44
Solar heat gain coefficient	0.83	0.53	0.59	0.57
Relative heat gain W/m ² -°K	649	435	475	464

Note:

- Above data is on monolithic substrate only.
- Calculation of U-value, Relative Heat Gain based on ASHRAE condition (GSBDL-GL)

Appendix N: Exhaust Air Energy Recovery Requirements

Climate Zone	% Outdoor Air at Full Design Airflow Rate							
	≥10% and <20%	≥20% and <30%	≥30% and <40%	≥40% and <50%	≥50% and <60%	≥60% and <70%	≥70% and <80%	≥80%
	Design Supply Fan Airflow Rate, cfm							
3B, 3C, 4B, 4C, 5B	NR	NR	NR	NR	NR	NR	NR	NR
0B, 1B, 2B, 5C	NR	NR	NR	NR	≥26000 0	≥12000	≥5000	≥4000
6B	≥28000	≥2650 0	≥11000	≥5500	≥4500	≥3500	≥2500	≥1500
0A, 1A, 2A, 3A, 4A, 5A, 6A	≥26000	≥16000	≥5500	≥4500	≥3500	≥2000	≥1000	≥120
7, 8	≥4500	≥4000	≥2500	≥1000	≥140	≥120	≥100	≥80

NR – Not required

Climate Zone	% Outdoor Air at Full Design Airflow Rate							
	≥10% and <20%	≥20% and <30%	≥30% and <40%	≥40% and <50%	≥50% and <60%	≥60% and <70%	≥70% and <80%	≥80%
	Design Supply Fan Airflow Rate, cfm							
3C	NR	NR	NR	NR	NR	NR	NR	NR
0B, 1B, 2B, 3B, 4C, 5C	NR	≥19500	≥9000	≥5000	≥4000	≥3000	≥1500	≥120
0A, 1A, 2A, 3A, 4B, 5B	≥2500	≥2000	≥1000	≥500	≥140	≥120	≥100	≥80
4A, 5A, 6A, 6B, 7, 8	≥200	≥130	≥100	≥80	≥70	≥60	≥50	≥40

NR – Not required

Source: ASHRAE Standard 169-2013

Appendix O: Philippine Stations and Climate Zones

Philippines (PHL.)	WMO#	Lat	Long	CZ	precipitation	
					mm	in.
BAGUIO	983280	16.42	120.6	2A	3886	145
CAGAYAN DE ORO	987460	8.48	124.63	OA	1667	66
CALAPAN	984310	13.42	121.18	OA	1885	74
CATANDUANES RADAR	984470	13.98	124.32	1A	3343	132
CATBALOGAN	985480	11.78	124.88	OA	2555	101
CLARK AB	983270	15.17	120.57	OA	2059	81
CUBI POINT NF	984260	14.8	120.27	OA	3685	145
DAET	984400	14.13	122.98	OA	3563	140
DAGUPAN	983250	16.05	120.33	OA	2429	96
DAVAO AIRPORT	987530	7.12	125.65	OA	1805	71
DUMAGUETE	986420	9.3	123.3	OA	1215	48
GEN. SANTOS	988510	6.12	125.18	OA	1044	41
IBA	983240	15.33	118.97	OA	3802	150
ILOILO	986370	10.7	122.57	OA	2024	80
INFANTA	984340	14.75	121.65	OA	3937	155
LAOAG	982230	18.18	120.53	OA	2226	88
LEGASPI	984440	13.13	123.73	OA	2618	103
LUMBIA AIRPORT	987470	8.43	124.28	OA	1888	74
MACTAN	986460	10.3	123.97	OA	1607	63
MALAYBALAY	987510	8.15	15.08	1A	2580	102
MANILA	984250	14.58	120.98	OA	2134	84
MASBATE	985430	12.57	123.62	OA	173	71
MUÑOZ	983290	15.72	120.9	OA	1941	76
NINOY AQUINO INTERN	984290	14.52	121	OA	2134	84
PUERTO PRINCESA	986180	9.75	116/73	OA	1541	61
ROXAS	985380	11.58	122.75	OA	1990	78
SAN JOSE	985310	12.35	121.03	OA	23.52	93
SANGLEY POINT	984280	14.5	120.92	OA	19.07	75
SCIENCE GARDEN	984300	14.63	121.02	OA	2134	84
SINAIT	982220	17.88	120.45	OA	2478	98
TACLOBAN	985500	11.25	125	OA	2241	88
TAGBILARAN	986440	9.6	123.85	OA	1411	56
TAYABAS	984270	14.03	121.58	1A	2439	96
ZAMBOANGA	988360	6.9	122.07	OA	1221	48

Source: ASHRAE Standard 169-2013